



# Nevada Non-Commercial Class A and B Study Guide



May 2010

# Table of Contents

<b>Foreword</b> .....	<b>4</b>
General Information .....	4
Non-Commercial Vehicle Classifications .....	4
What You Need To Know.....	5
<b>Section 1 - Driving Safely</b> .....	<b>6</b>
Basic Control of Your Vehicle .....	6
Accelerating .....	6
Shifting Gears .....	6
Controlling Speed.....	7
Steering.....	11
Braking .....	14
Be Aware of Your Surroundings.....	16
Looking Ahead .....	16
Use Your Mirrors .....	16
Signal Your Intentions.....	17
Communicate Your Presence .....	18
Managing Space .....	20
Space ahead.....	20
Space behind .....	20
Space to the sides.....	21
Space overhead.....	22
Space needed to cross or enter traffic .....	23
Driving at Night .....	24
Driver Factors.....	24
Roadway Factors .....	24
Vehicle Factors .....	25
Driving in Winter.....	25
Driving in Very Hot Weather.....	26
Seeing Hazards .....	28
Importance of Seeing Hazards.....	28
Hazardous Roads .....	28
Drivers Who Are Hazards .....	28
Emergencies .....	29
Tire Failure .....	29
Skid Control and Recovery .....	30
Accident Procedures.....	32
Fires .....	32
Staying Alert and Fit to Drive .....	34
<b>Section 2 - Transporting Cargo Safely</b> .....	<b>38</b>
Inspecting and Securing Cargo.....	38
Inspecting your cargo.....	38
Weight and balance .....	38
<b>Section 3 - Air Brakes</b> .....	<b>40</b>
The Parts of an Air Brake System.....	40
Dual Air Brakes .....	44
Walk-Around Inspection.....	45
Final Air Brake Check .....	45

Using Air Brakes .....	47
<b>Section 4 - Combination Vehicles .....</b>	<b>50</b>
Rollover risks .....	50
Brake early .....	51
Prevent trailer skids .....	51
Recognizing the skid .....	51
Stop using the brake .....	52
<b>Section 5 - Pre-Trip Vehicle Inspection Test .....</b>	<b>53</b>
All Vehicles .....	53
Engine Compartment Only .....	53
Cab Check/Engine Start .....	54
Air Brake Check (if equipped) .....	54
Light/Reflectors .....	55
Wheels .....	55
Tractor/Coupling .....	55
Trailer .....	56
<b>Section 6 - Basic Vehicle Control Skills Test .....</b>	<b>57</b>
Scoring .....	57
Exercises .....	57
<b>Section 7 - On-Road Driving Test .....</b>	<b>59</b>
Exercises .....	59
Clutch Usage (manual transmission) .....	59
Gear Usage (manual transmission) .....	59
Brake Usage .....	59
Lane Usage .....	59
How You Will Be Tested .....	60
Turns .....	60
Intersections .....	60
Curve .....	62
Upgrade .....	62
Downgrade .....	62

# Foreword

## General Information

The vehicles in the non-commercial classification are generally vehicles that are used for recreational purposes, or may include certain rental vehicles that meet the criteria of the below license classifications. However, trucks, buses, and vehicles operating at heavier weights are subject to certain laws, regulations, and restrictions that can vary from place to place.

You do not need a commercial driver's license to operate some vehicles that fall within the Gross Vehicle Weight Rating (GVWR) descriptions. The following are exempt from Nevada commercial driver's licensing requirements:

- Farmers transporting equipment, supplies, or products to or from a farm as long as the vehicle is:
  - Controlled and operated by a farmer, his family members, or employees;
  - Used within 150 miles of the farm;
  - Not being used as a common or contract motor carrier; or
  - Not transporting placarded amounts of hazardous materials.
- Active duty military personnel driving a military vehicle
- Firefighters operating emergency equipment

If you qualify for this exemption, you may apply for an "F" endorsement on your Nevada driver's license.

## Non-Commercial Vehicle Classifications

**Class A** May drive any combination of vehicles with a gross combination weight rating (GCWR) of 26,001 or more pounds, provided the vehicle being towed has a gross vehicle weight rating (GVWR) of more than 10,000 pounds; or

Any combination of vehicles not exceeding 70 feet in length with a gross combination weight rating of 26,000 pounds or less so long as the gross combination weight rating of the towed vehicles does not exceed the gross vehicle weight rating of the towing vehicle.

**Class B** May drive any single vehicle with a gross vehicle weight rating of 26,001 or more pounds, or any vehicle which is towing another vehicle which does not have a gross vehicle weight rating of more than 10,000 pounds.

**Class C** May drive any single vehicle or combination of vehicle that does not meet the definition of Class A or Class B. May include a low-speed vehicle, moped or a tri-mobility.

## What You Need To Know...

If You Are Applying For This	Study This
Class A License	Section 1, Driving Safely Section 2, Transporting Cargo Safely Section 4, Combination Vehicles Section 5, Pre-trip Inspection Section 6, Basic Skills Section 7, Drive Test
Class B License	Section 1, Driving Safely Section 2, Transporting Cargo Section 5, Pre-trip Inspection Section 6, Basic Skills Section 7, Drive Test
Any vehicle equipped with air brakes	Section 3, Air brakes

**Written tests** can be taken at all offices.

**Drive tests** are administered at the following offices:

555 Wright Way, Carson City  
 3920 East Idaho Street, Elko  
 178 North Avenue F, Ely  
 4110 Donovan Way, North Las Vegas  
 810 East Greg Street, Sparks  
 1137 South Main Street, Tonopah  
 3505 Construction Way, Winnemucca

# Section 1 - Driving Safely

## Basic Control of Your Vehicle

To drive a vehicle safely, you must be able to control its speed and direction. Safe operation of a vehicle requires skill in:

- Accelerating
- Shifting Gears
- Controlling Speed
- Steering
- Braking

You should wear your seat belt in a moving vehicle at all times and apply your parking brake when you leave your vehicle.

### Accelerating

Rough acceleration can cause mechanical damage. When pulling a trailer, rough acceleration can also damage the coupling. Start out smoothly and speed up gradually so the vehicle does not jerk. If you are starting your vehicle in motion from a stop and you apply power to the drive wheels and they begin to spin, take your foot off the accelerator.

If the vehicle has a manual transmission, don't roll back when you start. You may hit someone or something behind you. Partly engage the clutch before you take your right foot off of the brake. If you have to stop on an uphill grade, use the parking brake to hold the vehicle until the clutch engages. Release the parking brake only when you have applied enough engine power to keep from rolling back.

### Shifting Gears

It is important to shift gears correctly to keep control of the vehicle. If you can't get your vehicle into the right gear while driving, you will have less control.

#### Manual Transmission

*Basic method for shifting up* – Most heavy vehicles with manual transmissions require double clutching to change gears. This is the basic method:

1. Release accelerator, push in clutch and shift to neutral at the same time.
2. Release clutch.
3. Let engine and gears slow down to the RPM required for the next gear (this takes practice).
4. Push in clutch and shift to the higher gear at the same time.
5. Release clutch and press accelerator at the same time.

Shifting gears using double clutching requires practice. If you remain too long in neutral, you may have difficulty putting the vehicle into the next gear. If so, don't try to force it. Return to neutral, release clutch, increase engine speed to match road speed, and try again.

*Knowing when to shift* – There are two ways of knowing when to shift:

1. Engine speed (Revolutions Per Minute or RPM). Study the driver's manual for your vehicle and learn the operating RPM range. Watch your tachometer, and shift up when your engine reaches the top of the range.
2. Road speed (Miles Per Hour or MPH). Learn what speeds each gear is good for. By using the speedometer, you'll know when to shift up.

With either method, you may learn to use engine sounds to know when to shift.

*Basic method for shifting down*

1. Release accelerator, push in clutch and shift to neutral at the same time.
2. Release clutch.
3. Press accelerator, increase engine and gear speed to the RPM required in the lower gear.
4. Push in clutch and shift to lower gear at the same time.
5. Release clutch and press accelerator at the same time.

Downshifting, like upshifting requires knowing when to shift. Use either the tachometer or the speedometer and downshift at the right RPM or road speed.

Special conditions where you should downshift are:

- Starting down a hill – Slow down and shift down to a speed that you can control without using the brakes hard. Otherwise, the brakes can overheat and lose their braking power.
- Entering a curve – When you downshift for a curve, you should do so before you enter the curve. Slow down to a safe speed and shift down to the correct gear. This lets you use some power through the curve to help the vehicle be more stable while turning. It also lets you speed up as soon as you are out of the curve.

### Multi-Speed Rear Axles

Multi-speed rear axles and auxiliary transmissions are used on many vehicles to provide extra gears. They are generally controlled by a selector knob or switch on the gearshift lever of the main transmission. There are many different shift patterns. Learn the right way to shift gears in the vehicle you will drive.

### Automatic Transmissions

Some vehicles have automatic transmissions. You can select a low range to get greater engine braking when going down grades. The lower ranges prevent the transmission from shifting up beyond the selected gear (unless the governor RPM is exceeded). It is very important to use this braking effect when going down grades.

## **Controlling Speed**

### Stopping distance

The primary cause of fatal crashes is driving too fast. The speed at which you drive should be determined by your visibility and other driving conditions. These include traction, curves, traffic, and hills.

There are three things that add up to total stopping distance:

$$\begin{array}{r} \text{Perception Distance} \\ + \text{Reaction Distance} \\ + \text{Braking Distance} \\ \hline = \text{Total Stopping Distance} \end{array}$$

*Perception Distance* is the distance your vehicle travels from the time your eyes see a hazard until your brain recognizes it. The perception time for an alert driver is about  $\frac{3}{4}$  second. You will travel 60 feet in  $\frac{3}{4}$  second at 55 mph.

*Reaction Distance* is the distance traveled from the time your brain tells your foot to move from the accelerator until your foot is actually pushing the brake pedal. The reaction time of an average driver is about  $\frac{3}{4}$  second. You will travel an additional 60 feet in  $\frac{3}{4}$  second at 55 mph.

*Braking Distance* is the distance it takes to stop once the brakes are applied. The braking time for a heavy vehicle with good brakes is about  $4 \frac{1}{2}$  seconds. You will travel about 170 feet in  $4 \frac{1}{2}$  seconds at 55 mph.

*Total Stopping Distance* is the distance you will need to bring a vehicle to a stop. At 55 mph on dry pavement, the total stopping distance is the length of a football field. It will take about 6 seconds ( $60 + 60 + 170 = 290$  feet).

### The effect of speed on stopping distance

Whenever you double your speed, it takes about four times as much distance to stop, and your vehicle will have four times the destructive power if it crashes. High speeds greatly increase stopping distances. Slowing down a little might help prevent an accident.

### The effect of vehicle weight on stopping distance

The heavier the vehicle or the faster it is moving, the more work the brakes must do to stop it and the more heat they absorb. But the brakes, tires, springs, and shock absorbers on heavy vehicles are designed to work best when the vehicle is fully loaded. Actually empty trucks require **greater** stopping distances, because they have less traction. Also, an empty truck can bounce and lock up its wheels, giving poorer braking. (This is not usually the case with buses.)

You can't steer or brake your vehicle without traction. Traction is friction between the tires and the road. There are some road conditions that reduce traction and call for lower speeds.

### Speed and Curves

Drivers must adjust their speed for curves in the road. If you take a curve too fast, two things can happen. The wheels can lose their traction and continue straight ahead, so you skid off the road. Or, the wheels may keep their traction and the vehicle rolls over. Tests have shown that trucks with a high center of gravity can roll over at the posted speed limit for the curve.



Slow to a safe speed before you enter a curve. Braking in a curve is dangerous because it is easier to lock the wheels and cause a skid. Slow down as needed. Don't ever exceed the posted speed limit for the curve. Be in a gear that will let you accelerate slightly in the curve. This will help you keep control.

### Speed and distance ahead

You should choose a speed that lets you stop within the distance you can see ahead. Fog, rain, or other conditions may require that you slow down to be able to stop in the distance you can see. At night, you can't see as far with low beams as you can with high beams. Slow down when you must use low beams.

### Speed and traffic flow

When you're driving in heavy traffic, the safest speed is the speed of other vehicles. Vehicles going the same direction at the same speed are not likely to run into one another. If traffic is heavy and moving at 35 mph though the speed limit is 55 mph, the safest speed for your vehicle is most likely 35 mph. Also keep a safe following distance.

The main reason drivers exceed the speed limit is to save time. But anyone trying to drive faster than the speed of traffic will not be able to save much time. The risks involved are not worth it. If you go faster than the speed of other traffic, you have to keep passing other vehicles. This increases the chance of a crash. It is also more tiring. Fatigue increases the chance of a crash.

Going with the flow of traffic is safer and easier.

### Speed on Downgrades

In mountain driving, gravity plays a major role. On any upgrade, gravity slows you down. The steeper the grade, the longer the grade, and/or the heavier the load, the more you will have to use lower gears to climb hills or mountains. In coming down long, steep downgrades, gravity causes the speed of your vehicle to increase. Use a low gear and use proper braking techniques. The best way to choose a safe speed is based on your vehicle and its cargo. Select a safe speed that is within the posted speed. If a speed limit is posted or there is a sign indicating "Maximum Safe Speed," never exceed the speed shown. Look for and heed warning signs indicating the length and steepness of the grade.

The principal way you should control your speed going down long and/or steep downgrades is the braking effect of the engine. The braking effect of the engine is greatest when it is near the governed RPMs and the transmission is in the lower gears. If you are driving a new truck with a manual transmission and are taking a long, steep downhill grade, you will probably have to use a lower gear than you would use to climb the hill. Save your brakes so you will be able to slow or stop as required by road and traffic conditions.

Shift the transmission to a low gear before starting down the grade. Do not try to downshift after your speed has already built up. You will not be able to shift into a lower gear. Forcing an automatic transmission into a lower gear at high speed could damage the transmission and lead to loss of all engine braking effect.

You must go slowly enough so your brakes can hold you back, if needed, without getting too hot. If the brakes become too hot, they may start to "fade." This means you have to apply them

harder and harder to get the same stopping power. If you continue to use the brakes hard, they can keep fading until you cannot slow down or stop at all.

It is always important for the brakes to be adjusted right. However, it is especially important when going down steep grades. If you have a brake modulator, the brake system should be balanced to give about the same braking at each set of wheels. Otherwise, some brakes will do more work than others. They will heat up and lose some of their stopping power.

### Escape Ramps

Escape ramps have been built on many steep mountain grades. Escape ramps are made to stop runaway vehicles safely without injuring drivers and passengers and to help avoid damage to vehicles. Escape ramps use a long bed of loose soft material (pea gravel) to slow a runaway vehicle, sometimes in combination with an upgrade.

Know escape ramp locations on your route. Signs show drivers where ramps are located. Escape ramps save lives, equipment, and cargo. Use them if you lose your brakes.

### Slippery Surfaces

It will take longer to stop and it will be harder to turn without skidding when the road is slippery. You must drive slower to be able to stop in the same distance as on a dry road. Wet roads can double stopping distance. On a wet road, you should reduce your speed by about one-third (e.g., slow from 55 mph to about 35 mph). On packed snow, reduce speed by a half or more. If the surface is icy, reduce speed to a crawl. If the road you are driving on becomes very slippery due to glare ice, stop driving as soon as you can safely do so.

The following are some safety guidelines:

- Start gently and slowly – When first starting, get the feel of the road. Don't hurry. If you use too much power, the drive wheels may spin and you could lose control.
- Adjust turning and braking to conditions – Make turns as gently as possible. Don't brake any harder than necessary and don't use the engine brake or speed retarder. (They can cause the driving wheels to skid on slippery surfaces.)
- Adjust speed to conditions – Don't pass slower vehicles unless necessary. Go slow and watch far enough ahead to keep a steady speed. Avoid having to slow down and speed up. Take curves at slower speeds and don't brake while in curves. Be aware that as the temperature rises to the point where ice begins to melt, the road becomes even more slippery. Slow down more.
- Adjust space to conditions – Don't drive alongside other vehicles. Keep a longer following distance. When you see a traffic jam ahead, slow down or stop to wait for it to clear. Try hard to anticipate stops early and slow down gradually.
- Wet brakes – When driving in heavy rain or deep standing water, your brakes will get wet. Water in the brakes can cause the brakes to be weak, to apply unevenly, or to grab. This can cause lack of braking power, wheel lockups, pulling to one side or the other and jackknife if you pull a trailer.
- Avoid driving through deep puddles or flowing water if possible. If not, you should:
  - Slow down.
  - Place transmission in a low gear.

- Gently put on the brakes. This presses the linings against the brake drums or discs and keeps mud, silt, sand, and water out of your brakes, keeping your brakes working.
- Increase engine RPM and cross the water while keeping light pressure on the brakes.
- When out of the water maintain light pressure on the brakes for a short distance to heat them up and dry them out.
- Make a test stop when safe to do so. Make sure no one is following, and then apply the brakes to be sure they work right. If not, dry out further as described above. (CAUTION: Do not apply too much brake pressure and accelerator at the same time or you can overheat brake drums and linings.)

### Identifying Slippery Surfaces

Sometimes it's hard to know if the road is slippery. Here are some signs of slippery roads.

- *Shady areas* – Shady parts of the road will remain icy and slippery long after open areas have melted.
- *Bridges* – When the temperature drops, bridges will freeze before the road will. Be especially careful when the temperature is close to 32° F.
- *Melting Ice* – Slight melting will make ice wet. Wet ice is much more slippery than ice that is not wet.
- *Black Ice* – Black ice is a thin layer that is clear enough that you can see the road underneath it. It makes the road look wet. Any time the temperature is below freezing and the road looks wet, watch out for black ice.
- *Vehicle Icing* – An easy way to check for ice is to open the window and feel the front of the mirror, mirror support, or antenna. If there's ice on these, the road surface is probably starting to ice up.
- *Just after rain begins* – Right after it starts to rain, the water mixes with oil left on the road by vehicles. This makes the road very slippery. If the rain continues, it will wash the oil away.
- *Hydroplaning* – In some weather, water or slush collects on the road. When this happens, your vehicle can hydroplane. It's like water skiing. The tires lose their contact with the road and have little or no traction. You may not be able to steer or brake. If the vehicle is hydroplaning, do not use the brakes to slow down, release the accelerator. This will slow your vehicle and let the wheels turn freely. If the drive wheels start to skid and you have a manual transmission, push in the clutch to let them turn freely. It does not take a lot of water to cause hydroplaning. Hydroplaning can occur at speeds as low as 30 mph if there is a lot of water. Hydroplaning is more likely if tire pressure is low or the tread is worn. The grooves in a tire can carry water away; if they aren't deep, they won't work. Be especially careful when driving through puddles. The water is often deep enough to cause hydroplaning.

## **Steering**

### Keep Both Hands on the Steering Wheel

The proper way to hold a steering wheel is with both hands on opposite sides of the wheel. In order to turn quickly, you must have a firm grip on the steering wheel. The best way to have both hands on the wheel if there is an emergency is to keep them there all the time. If you do

not have both hands on the wheel, the wheel could pull away from you if you hit a curb or a pothole (chuckhole).

Stopping is not always the safest thing to do in an emergency. When you don't have enough room to stop, you may have to steer away from what's ahead. Remember, you can always turn to miss an obstacle more quickly than you can stop. (However, top-heavy vehicles and tractors with multiple trailers may flip over.)

### Steering to Avoid a Crash

A quick turn can be made safely if it's done the right way. Here are some points that safe drivers use:

- Do not apply the brake while you are turning. It's very easy to lock your wheels while turning. If that happens, you may skid out of control.
- Do not turn any more than needed to clear whatever is in your way. The more sharply you turn, the greater the chances of a skid or rollover.
- Be prepared to "counter steer," that is, to turn the wheel back in the other direction, once you've passed whatever was in your path. Unless you are prepared to counter steer, you won't be able to do it quickly enough. You should think of emergency steering and counter steering as two parts of one driving action.

### Where to Steer

If an oncoming driver drifts into your lane and is headed straight for you, steer to your right is best action to take. If that driver realizes what has happened, the natural response will be to return to his or her own lane. If something is blocking your path, the best direction to steer will depend on the situation.

If you have been using your mirrors, you'll know which lane is empty and can be safely used.

- If the shoulder is clear, going right may be best. No one is likely to be driving on the shoulder but someone may be passing you on the left.
- If you are blocked on both sides, a move to the right may still be best. At least you won't force anyone into an opposing traffic lane and a possible head-on collision.

### Leaving the Road

In some emergencies, you may have to drive off the road. It may be less risky than facing a collision with another vehicle.

Most shoulders are strong enough to support the weight of a large vehicle and, therefore, offer an available escape route. Here are some guidelines if you need to leave the road:

- *Avoid Braking* – If possible, avoid braking until your speed has dropped to about 20 mph. Then brake very gently to avoid skidding on a loose surface.
- *Keep one set of wheels on pavement if possible* – This helps to maintain control.
- *Stay on the Shoulder* – If the shoulder is clear, stay on it until your vehicle has come to a stop. Signal and check your mirrors before moving back onto the road when it is safe.

- *Returning to the Road* – If you are forced to return to the road before you can stop, use the following procedure:
  - Hold the wheel tightly and turn sharply enough to get right back on the road safely.
  - Don't try to edge gradually back on the road. If you do, your tires might grab unexpectedly and you could lose control.

When both front tires are on the paved surface, counter steer immediately. The two turns should be made as a single “steer-counter-steer” move.

### Backing a Trailer

When backing a car, straight truck, or bus, you turn the top of the steering wheel toward the direction you want to go. When backing a trailer, you turn the steering wheel in the opposite direction. Once the trailer starts to turn, you must turn the wheel the other way to follow the trailer.

Because you cannot see everything behind your vehicle, backing up is always dangerous. Avoid backing whenever you can. When you park, try to park so you will be able to pull forward when you leave.

When you do have to back up with a trailer, try to position your vehicle so you can back in a straight line. Additionally, here are a few simple safety rules:

*Look at your path* – Look at your line of travel before you begin. Get out and walk around the vehicle. Check your clearance to the sides and overhead in and near the path your vehicle will take.

*Back slowly* – Always back as slowly as possible. Use the lowest reverse gear. That way you can easily correct any steering errors. You also can stop quickly if necessary.

*Use the mirrors* – The mirrors will help you see whether the trailer is drifting to one side or the other.

*Correct drift immediately* – As soon as you see the trailer getting off course, correct it by turning the top of the steering wheel in the direction of the drift.

*Use driver-side backing* – Back and turn toward the driver's side whenever possible especially on a curved path. Back to the driver's side so you can see well. Backing toward the right side is very dangerous because you can't see as well. If you back and turn toward the driver's side, you can watch the rear of your vehicle by looking out the side window. Use driver-side backing even if it means going around the block to put your vehicle in this position. The added safety is worth it.

*Pull forward* – When backing a trailer, make pull-ups to reposition your vehicle as needed.

*Use a helper* – If possible, a helper should be used whenever you have to back your vehicle. There are blind spots you can't see. The helper should stand near the back of your vehicle where you can see them. Before you begin backing, work out a set of hand signals that you both understand. Agree on a signal for “STOP.”

## **Braking**

If somebody suddenly pulls out in front of you, your natural response is to hit the brakes. This is a good response if there's enough distance to stop and you use the brakes correctly.

You can use the “controlled braking” or the “stab braking” method to keep a vehicle in a straight line when braking. This will then allow you to turn if it becomes necessary.

### Controlled braking

With this method, you apply the brakes as hard as you can without locking the wheels.

- Keep steering wheel movements very small while doing this.
- If you need to make a larger steering adjustment or if the wheels lock, release brakes.
- Reapply the brakes as soon as you can.

### Stab Braking

- Apply your brakes all the way.
- Release brakes when wheels lock up.
- As soon as the wheels start rolling, apply the brakes fully again. (It can take up to one second for the wheels to start rolling after you release brakes. If you reapply the brakes before the wheels start rolling, the vehicle won't straighten out.)

Emergency braking does not mean pushing down on the brake pedal as hard as you can. That will only keep the wheels locked up and cause a skid. If the wheels are skidding, you cannot control the vehicle.

### Retarders

Some vehicles have “retarders.” Retarders help slow a vehicle, reducing the need for using your brakes. They reduce brake wear and give you another way to slow down. There are many types of retarders (exhaust, engine, hydraulic, electric). All retarders can be turned on or off by the driver. On some, the retarder power can be adjusted. When turned “on,” the retarders apply their braking power, to the drive wheels only, whenever you let up on the accelerator pedal all the way.

**Caution:** Retarders can cause the drive wheels to skid when the drive wheels have poor traction. Therefore, you should turn the retarder off whenever the road is wet, icy, or snow covered.

### Brake Failure

Brakes kept in good condition rarely fail. (Air brakes are discussed in Section 3) Most hydraulic brake failures occur for one of three reasons:

- Loss of hydraulic pressure.
- Brake fade on long hills.
- Brake fade due to being out of adjustment.

## Loss of Hydraulic Pressure

When the system won't build up pressure, the brake pedal will feel spongy or go to the floor. Here are some things you can do:

1. *Downshift* – Putting the vehicle into a lower gear will help to slow the vehicle.
2. *Pump the brakes* – Sometimes pumping of the brake pedal will generate enough hydraulic pressure to stop the vehicle.
3. *Use the parking brake* – The parking or emergency brake is separate from the hydraulic brake system. Therefore, it can be used to slow the vehicle. However, be sure to press the release button or pull the release lever at the same time you use the emergency brake so you can adjust the brake pressure and keep the wheels from locking up.
4. *Find an escape route* – While slowing the vehicle, look for an escape route (an open field, side-street or escape ramp). Turning uphill is a good way to slow and stop the vehicle. Make sure the vehicle does not start rolling backward after you stop. Put it in low gear, apply the parking brake, and if necessary, roll back into some obstacle that will stop the vehicle.
5. *Brake failure on Downgrades* – Going slow enough and braking properly will almost always prevent brake failure on long down-grades. Once the brakes have failed, however, you will need to look outside your vehicle for something to stop it.
  - Your best hope is an escape ramp. If there is one, there'll be signs telling you about it. Use it. Ramps are usually located a few miles from the top of the downgrade. Every year, hundreds of drivers avoid injury or damage to their vehicles by using escape ramps. Some escape ramps use soft gravel that resists the motion of the vehicle and brings it to a stop. Others turn uphill, using the hill to stop the vehicle and soft gravel to hold it in place.
  - Any driver who loses brakes going downhill should use an escape ramp if it's available. If you don't use it, your chances of having a serious crash may be much worse.
  - If no escape ramp is available, take the least hazardous escape route you can – such as an open field or a side road that flattens out or turns uphill. Make the move as soon as you know your brakes don't work. The longer you wait, the faster the vehicle will go and the harder it will be to stop.

## Brake Fading on Long Hills

Brakes are designed so brake shoes or pads rub against the brake drum or disks to slow the vehicle. Braking creates heat, but brakes are designed to take a lot of heat. However, brakes can fade or fail from excessive heat caused by using them too much and not relying on the engine braking effect. To prevent brake fade, you should select a gear which will keep your vehicle to a safe speed on steep downgrades.

## Brake Fade Due to Being Out of Adjustment

Brakes also can fade because of being out of adjustment. To safely control a vehicle, every brake must do its share of the work. If some brakes are out of adjustment, they will not be doing their share. The other brakes can overheat and fade and there will not be enough braking available to control the vehicle. Brakes can get out of adjustment when they are used a lot and should be checked often. Also, brake linings wear faster when they are hot.

## Proper Braking Technique

**Remember:** The use of brakes on a long and/or steep downgrade is only a supplement to the braking effect of the engine. Once the vehicle is in the proper low gear, the following is a proper braking technique:

- ❖ Apply the brakes just hard enough to feel a definite slowdown.
- ❖ When your speed has been reduced to approximately 5 mph below your “safe” speed, release the brakes. [This brake application should last for about three (3) seconds.]
- ❖ When your speed has increased to your “safe” speed, repeat the steps above. For example: if your “safe” speed is 40 mph, you now apply the brakes hard enough to gradually reduce your speed to 35 mph and then release the brakes. Repeat this as often as necessary until you have reached the end of the downgrade.

## **Be Aware of Your Surroundings**

To be a safe driver, you need to know what’s going on all around your vehicle. Not using your eyes properly is a major cause of accidents.

**Looking Ahead** – All drivers look ahead, but many don’t look far enough ahead.

- *Importance of looking far enough ahead* – Because stopping or changing lanes can take a lot of distance, knowing what the traffic is doing on all sides is very important. You need to look well enough ahead to make sure you have room to make these moves safely.
- *How far ahead to look* – A driver should look 12 to 15 seconds ahead of the vehicle while driving. At lower speeds, that’s about one block. At highway speeds, it’s about a quarter of a mile. If you’re not looking that far ahead, you may have to stop too quickly or make lane changes. Looking 12 to 15 seconds ahead doesn’t mean not paying attention to things that are closer to you. Good drivers shift their attention back and forth, near and far.
- *Look for traffic* – Look for vehicles coming onto the highway, into your lane, or turning. Watch for brake lights from slowing vehicles. By seeing these things far enough ahead, you can change your speed or change lanes if necessary to avoid a problem.
- *Look for road conditions* – Look for hills and curves, or anything that may require you to reduce your speed. Pay attention to traffic signals and signs. If a light has been green for some time, anticipate the change, start slowing down, and be ready to stop. Traffic signs may alert you to road conditions where you may have to change speed.

## **Use Your Mirrors**

It’s important to know what is going on behind and to the sides of your vehicle. You should adjust your mirrors prior to starting a trip. Check your mirrors regularly and check more often in special situations. However, remember there are “blind spots” that your mirrors cannot show you.

- *Traffic* – Check the mirrors for vehicles on either side and in back of you. In an emergency, you may need to know if you can make a quick lane change.



- *Check your vehicle* – Use the mirrors to keep an eye on your tires. It’s one way to spot a tire fire. If you’re carrying open cargo, you can use the mirrors to check it. Look for loose straps, ropes, or chains. Watch for a flapping or ballooning tarp.
- *Special situations* – Special situations require more than regular mirror checks. These are lane changes, turns, merges, and tight maneuvers.
  - *Lane changes* – You need to check your mirror to make sure no one is along side you or about to pass you. If you saw a car approaching from the rear, then the next time you check your mirror you do not see the car, you should wait to change lanes until you are sure the car isn’t in your blind spot. Check your mirrors:
    - Before you change lanes to make sure there’s enough room;
    - After you have signaled, to check that no one has moved from your blind spot;
    - Right after you start the lane change to double-check that your path is clear; and
    - After you complete the lane change.
  - *Turns* – Use your mirrors to check where the rear of your vehicle is while you make turns. This will help make sure you don’t hit anything.
  - *Merges* – Use your mirrors to make sure the gap in traffic is large enough for you to enter safely.
  - *Tight maneuvers* – Any time you are driving in close quarters, use your mirrors often to make sure you have enough clearance.
- *How to use mirrors* – Use mirrors correctly by checking them quickly and understanding what you use.
  - *Checking quickly* – When you use your mirrors while driving on the road, check quickly. Look back and forth between the mirrors and the road ahead. Don’t focus on the mirrors for too long, otherwise, you will travel quite a distance without knowing what’s happening ahead.
  - *Understanding what you see* – Many large vehicles have curved (convex, “fisheye,” “spot,” “bugeye”) mirrors that show a wider area than flat mirrors. This is often helpful. But everything appears smaller in a convex mirror than it would if you were looking at it directly. Things also seem farther away than they really are. It’s important to realize this and to allow for it.

## Signal Your Intentions

Other driver’s can’t know what you are going to do until you tell them. Signaling what you intend to do is important for safety, and it’s the law. Here are some general rules for signaling.

*Turns* – There are three good rules for using turn signals:

1. Signal early. Signal well before you turn. It’s the best way to keep others from trying to pass you.
2. Signal continuously. You need both hands on the wheel to turn safely. Don’t cancel the signal until you have completed the turn.
3. Cancel your signal. Don’t forget to turn off your turn signal after you’ve turned if you don’t have self-cancelling signals.

*Lane changes* – Signal early and change lanes slowly and smoothly. This will allow a driver you didn’t see to honk the horn and/or avoid your vehicle.

*Slowing Down* – Warn drivers behind you when you see you'll need to slow down. A few light taps on the brake pedal – enough to flash the brake lights – should warn following drivers. Use the 4-way emergency flashers when you are driving very slow or are stopped. Warn other drivers in any of the following situations:

- *Trouble ahead* – The size of your vehicle may make it hard for drivers behind you to see hazards ahead. If you see a hazard that will require slowing down, warn the drivers behind by flashing your brake lights.
- *Tight turns* – Most car drivers don't know how slow you have to go to make a tight turn in a large vehicle. Warn drivers behind you by braking early and slowing gradually.
- *Stopping on the road* – Truck and bus drivers sometimes stop in the road to unload cargo or passengers or stop at a railroad crossing. Warn following drivers by flashing your brake lights. Don't stop suddenly.
- *Driving slowly* – Drivers often do not realize how fast they are catching up to a slow vehicle until they are very close. If you must drive slowly, alert following drivers by turning on your emergency flashers if it is legal. (Laws regarding the use of flashers differ from one state to another. Check the laws for each state where you will be driving.)
- *Don't direct traffic* – Some drivers try to help out others by signaling when it is safe to pass. YOU SHOULD NOT DO THIS. You could cause an accident. You could be blamed, and it could cost you many thousands of dollars.

## **Communicate Your Presence**

Other drivers may not notice your vehicle even when it's in plain sight. Let them know you're there to help prevent accidents.

- *When passing* – Whenever you are about to pass a vehicle, pedestrian, or bicyclist, assume they don't see you. They could suddenly move in front of you. When it is legal, tap the horn lightly. At night, flash your lights from low to high beam and back. Don't leave your high beams on until you have completely passed the vehicle. Drive carefully enough to avoid a crash even if they don't see or hear you.
- *When it's hard to see* – At dawn or dusk, or in rain or snow, it can be hard to see and be seen. If you are having trouble seeing other vehicles, other drivers will have trouble seeing you. You can let others know you are there by turning on the low beam headlights, not just the identification or clearance lights.
- *When parked at the side of the road* – When you pull off the road and stop, always be sure to turn on the 4-way emergency flashers. This is especially important at night. Don't trust the taillights to give warning. Drivers have crashed into the rear of a parked vehicle because they thought it was moving normally.

If you must stop on the road or the shoulder of a road, you should put out your reflective triangles within ten minutes. Warning devices must always be carried in your vehicle. Place your warning devices at the following locations:

- On the traffic side of the vehicle, within ten (10) feet of the front or rear corners to mark the location of the vehicle. (Fig. 1-1)

Figure 1-1  
Warning Device Placement:  
Two-Lane (traffic in both directions) or  
Undivided Highway

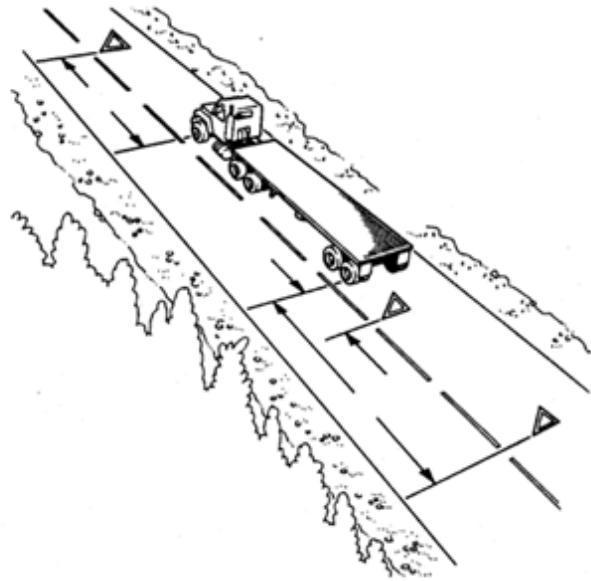

- Approximately 100 feet behind and ahead of the vehicle on the shoulder or in the lane you are stopped in. (Fig. 1-1)
- If a hill or curve keeps on-coming drivers from seeing the vehicle within 500 feet, move the rear reflective triangle back down the road. (Fig 1-2)

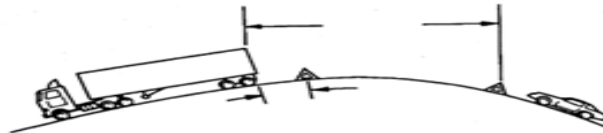
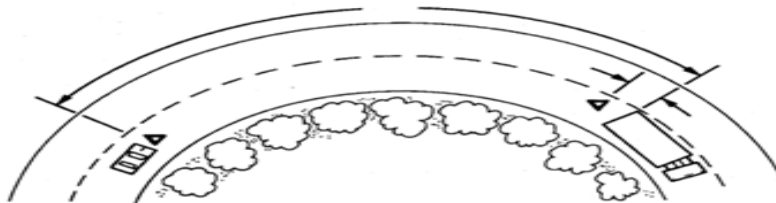

Figure 1-2  
Warning Device Placement:  
Obstructed View



- If you must stop on or by a one-way divided highway, place warning devices 10 feet, 100 feet, and 200 feet toward the approaching traffic. (Fig. 1-3)

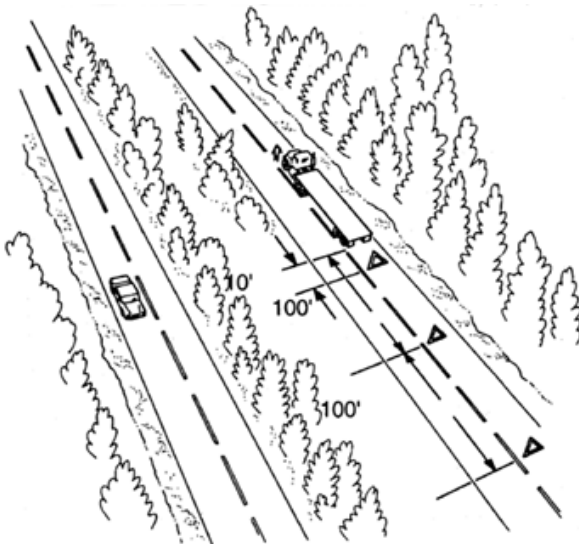

Figure 1-3  
Warning Device Placement:  
One-Way or Divided Highway

- When putting out the triangles, hold them between yourself and the oncoming traffic for your own safety and so other drivers can see you.

### Use your horn when needed

Your horn can let others know you are there. It can help to avoid a crash. Use your horn when needed. However, it can startle others and could be dangerous when used unnecessarily.

## **Managing Space**

To be a safe driver, you need space all around your vehicle. When things go wrong, space gives you time to think and to take action. To have space available when something goes wrong, you need to manage your space. While this is true for all drivers, it is especially important for large vehicles. They take up more space and require more space for stopping and turning.

### **Space ahead**

Of all of the space around your vehicle it is the area ahead of the vehicle, the space you are driving into, that is most important. You need space ahead in case you must suddenly stop. According to accident reports, the vehicle that trucks and buses most often run into is the one in front of them. The most frequent cause is *following too closely*. Remember, if the vehicle ahead of you is smaller than yours, it can probably stop faster than you can. You may crash if you are following too closely.

### How much space?

How much space should you keep in front of you? One good rule says you need at least one second for each 10 feet of vehicle length at speeds below 40 mph. At greater speeds, you must add one second for safety. For example, if you are driving a 40-foot vehicle at 35 mph and the road is dry and visibility is good, you should leave 4 seconds between you and the vehicle ahead. In a 60-foot rig, you will need 6 seconds. Over 40 mph, you would need 5 seconds for a 40-foot vehicle and 7 seconds for a 60-foot vehicle.

To know how much space you have, wait until the vehicle ahead passes a shadow on the road, a pavement marking, or some other clear landmark. Then count off the seconds like this: "One thousand-and-one, one thousand-and-two" and so on, until you reach the same spot. Compare your count with the rule of one second for every 10 feet of length. If you are driving a 40-foot truck and only counted up to 2 seconds, you're too close. Drop back a little and count again until you have 4 seconds of following distance (or 5 seconds if you're going over 40 mph). After a little practice, you will know how far back you should be. Remember to add one second for speeds above 40 mph. Also remember that when the road is slippery, you need much more space to stop.

### **Space behind**

You can't stop others from following you too closely, but there are things you can do to make it safer:

- Stay to the right; and
- Deal with tailgaters safely.

### Stay to the right

Heavy vehicles are often tailgated when they can't keep up with the speed of traffic. This often happens when you're going uphill. If a heavy load is slowing you down, stay in the right lane if you can. Going uphill, you should not pass another slow vehicle unless you can get around quickly and safely.

### Dealing with tailgaters

In a large vehicle, it's often hard to see whether a vehicle is close behind you. When you are traveling slowly, drivers trapped behind often follow closely. Also, many car drivers follow large vehicles closely during bad weather, especially when it is hard to see the road ahead.

If you find yourself being tailgated, here are some things you can do to reduce the chances of a crash:

- Avoid quick changes. If you have to slow down or turn, signal to reduce the chances of a crash.
- Increase your following distance. Opening up room in front of you will help you to avoid having to make sudden speed or direction changes. It also makes it easier for the tailgater to get around you.
- Don't speed up. It's safer to be tailgated at a low speed than a high speed.
- Don't flash your brake lights or turn on your tail lights. Follow the suggestions above.

### **Space to the sides**

Commercial vehicles are often wide and take up most of a lane. Safe drivers will manage what little space they have. You can do this by keeping your vehicle centered in your lane and avoid driving alongside others.

*Staying centered in a lane* – You need to keep your vehicle centered in the lane to keep safe clearance on either side. If your vehicle is wide, you have little room to spare.

*Traveling next to others* – There are two dangers in traveling alongside other vehicles:

- Another driver may change lanes suddenly and turn into you; and
- You may be trapped when you need to change lanes.

*Strong winds* – Strong winds make it difficult to stay in your lane. The problem is usually worse for lighter vehicles and a double with empty trailers will have the most difficulty staying in its lane. Winds are especially a problem when coming out of tunnels. Don't drive alongside others if you can avoid it.

Find an open spot where you aren't near other traffic. When traffic is heavy, it may be hard to find an open spot. If you must travel near other vehicles, try to keep as much space as possible between you and them. Also, drop back or pull forward so that you are sure the other driver can see you.

## Space overhead

Hitting overhead objects is a danger. Make sure you always have overhead clearance.

- Don't assume that the height posted at bridges and overpasses are correct. Repaved roads or packed snow may have reduced the clearances since the heights were posted.
- The weight of a vehicle changes its height. An empty van is higher than a loaded one. Going under a bridge when you were loaded does not mean that you can do it when you are empty.
- If you doubt you have safe space to pass under an object, go slowly. If you aren't sure you can make it, take another route. Warnings may or may not be posted on low bridges or underpasses.
- Some roads can cause a vehicle to tilt. There can be a problem clearing objects along the edge of the road, such as signs or trees. Where this is a problem, drive a little closer to the center of the road.
- Before you back into an area, get out and check for overhanging objects, such as trees, branches, or electric wires. It's easy to miss seeing them while you are backing. (Also check for other hazards at the same time.)

Many drivers forget about the space under their vehicles. That space can be very small when a vehicle is heavily loaded. Railroad tracks can stick up several inches. This is often a problem on dirt roads and in unpaved yards where the surface around the tracks can wear away. Don't take a chance on getting hung up halfway across. Drainage channels across roads can cause the end of some vehicles to drag. Cross such depressions carefully.

The space around a truck or bus is important in turns. Because of wide turning and off tracking, large vehicles can hit other vehicles or objects during turns.

## Right turns

Here are some rules to help prevent right-turn crashes:

- Turn slowly to give yourself and others more time to avoid problems.
- If you are driving a truck or bus that cannot make the right turn without swinging into another lane, turn wide as you complete the turn. Keep the rear of your vehicle close to the curb. This will stop other drivers from passing you on the right. See Figure 1-4, page 23.
- Don't turn wide to the left as you start the turn. A following driver may think you are turning left and try to pass you on the right. You may crash into the other vehicle as you complete your turn. See Figure 1-5, page 23.
- If you must cross into oncoming traffic to make a turn, watch out for vehicles coming toward you. Give them room to go by or stop. However, don't back up for them because you might hit someone behind you.

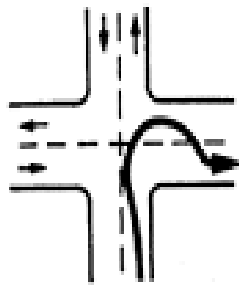

Figure 1-4  
Do This

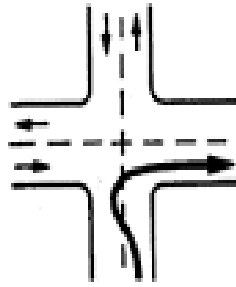

Figure 1-5  
Don't Do This

## Left turns

On a left turn, make sure you have reached the center of the intersection before you start the left turn. If you turn too soon, the left side of your vehicle may hit another vehicle because of off-tracking.

If there are two turning lanes, always take the right-hand turn lane. Don't start in the inside lane, because you may have to swing right to make the turn. Drivers on your right may be hard for you to see. You may crash into them.

Figure 1-6  
If there are two left-turn lanes, use the right-hand lane.

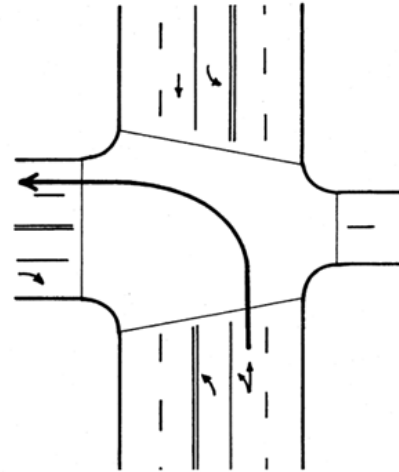

## **Space needed to cross or enter traffic**

Be aware of the size and weight of your vehicle when you cross or enter traffic. Here are some important things to keep in mind:

- Because of slow acceleration and the space large, heavy vehicles require, you may need a much larger gap to enter traffic than you would in a car.
- Acceleration varies with the load. Allow more room if your vehicle is heavily loaded.
- Before you start across a road, make sure you can get all the way across before traffic reaches you.

### TEST YOUR KNOWLEDGE

1. How do you find out how many seconds of following distance space you have?
2. If you are driving a 30-foot vehicle at 55 mph, how many seconds of following distance should you allow?
3. You should decrease your following distance if somebody is following you too closely. True or False?
4. If you swing wide to the left before turning right, another driver may try to pass you on the right. True or False?

## Driving at Night

You are at greater risk when you drive at night. Drivers can't see hazards as easily as in daylight, so they have less time to respond. Drivers caught by surprise are less able to avoid a crash. The problems of night driving involve the driver, the roadway, and the vehicle. We will discuss each of these factors.

### Driver Factors

Vision, glare, fatigue and lack of alertness are all factors that need to be considered when driving at night.

- *Vision* – People can't see as sharply at night or in dim light. Also, the eyes need time to adjust to seeing in dim light. Most people have noticed this when walking from daylight into a dark room.
- *Glare* – Glare from your headlights can cause problems for drivers coming toward you. They can also bother drivers going in the same direction you are when your lights shine in their rearview mirror. Older drivers are especially bothered by glare. Most people have been temporarily blinded by camera flash units or by the high beams of an oncoming vehicle. It can take several seconds to recover from glare. Even two seconds of glare blindness can be dangerous. A vehicle going 55 mph will travel more than half the distance of a football field during that time. Don't look directly at bright lights when driving. Look at the right lane or edge marking if possible. Dim your lights within 500 feet of an oncoming vehicle and when following another vehicle within 300 feet. If other drivers don't put their low beams on, don't try to "get back at them" by switching to your high beams. This increases glare for oncoming drivers and increases the chance of a crash.
- *Fatigue and lack of alertness* – Fatigue (being tired) and lack of alertness are bigger problems at night. The body's need for sleep is beyond a person's control. Most people are less alert at night, especially after midnight. This is particularly true if you have been driving for a long time. A fatigued driver may not see hazards as soon or react as quickly, so the chance of a crash is greater. If you are sleepy, the only safe cure is to get off the road and get some sleep. If you don't, you risk your life and the lives of others.

### Roadway Factors

Roadway factors such as lighting and other drivers are more apparent when driving at night.

- *Poor lighting* – In the daytime, there is usually enough light to see well. This is not true at night. Some areas may have bright streetlights, but many areas will have poor lighting. On most roads, you will probably have to depend entirely on your headlights. Less light means you will not be able to see hazards as well as in daytime. Many accidents at night involve pedestrians, bicyclists, and animals that are difficult to see in low light. Even with street lights, traffic signals and hazards can be hard to see against a background of signs, shop windows, and other lights. Drive slower when lighting is poor or confusing. Drive slowly enough to be sure you can stop in the distance you can see ahead. If you cannot see well with your headlights, use your high beams when legal and keep your interior light off.



- *Drunk Drivers* – Drunk drivers and drivers under the influence of drugs are a hazard to themselves and to you. Be especially alert around the closing times for bars and taverns. Watch for drivers who have trouble staying in their lane or maintaining speed, stop without reason, or show other signs of being under the influence of alcohol or drugs.

## Vehicle Factors

- *Headlights* – At night, your headlights will usually be the main source of light for you to see and for others to see you. You can't see nearly as much with your headlights as you can during the daytime. With low beams, you can see ahead about 250 feet and with high beams about 350-500 feet. You must adjust your speed to keep your stopping distance within your sight distance. This means going slow enough to be able to stop within the range of your headlights. Otherwise, by the time you see a hazard, you will not have time to stop. Use high beams when it is safe and legal to do so. Use them when you are not within 500 feet of an approaching vehicle. Also, don't let the inside of your vehicle get too bright. This makes it harder to see outside. Keep the interior light off and adjust your instrument lights as low as you can and still read the gauges. Night driving can be more dangerous if you have problems with your headlights. Dirty headlights may give only half the light they should, cutting down your visibility and making it harder for others to see you. Make sure your lights are clean and working. Have a qualified person make sure they are adjusted properly. Headlights that are out of adjustment will not provide the directional light intended and may be directed inappropriately at other drivers.
- *Other Lights* – In order for you to be seen easily, your reflectors, marker lights, clearance lights, taillights, and identification lights must be clean and working properly.
- *Turn Signals and Brake Lights* – At night, your turn signals and brake lights are even more important for telling other drivers what you intend to do. Make sure you have clean, working turn signals and stop lights.
- *Windshields and Mirrors* – It is more important at night than in the daytime to have a clean windshield and mirrors. Bright lights at night can cause dirt on your windshield or mirrors to create a glare of its own, blocking your view. Most people have experienced driving toward the sun just as it has risen or is about to set and found that they can barely see through the windshield that seemed to look okay in the middle of the day. Clean your windshield on the inside and outside for safe driving.

## Driving in Winter

Make sure your vehicle is ready for driving in winter weather. You should make a regular pre-trip inspection, paying extra attention to the following items:

- *Coolant and Antifreeze Levels* – Make sure the cooling system is full and there is enough anti-freeze in the system to protect against freezing. This can be checked with a special coolant tester.
- *Defrosting and Heating Equipment* – Make sure the defrosters work. They are needed for safe driving. Check that the heater is working properly before starting your trip and that you know how to operate it. If you use other heaters and expect to need them (e.g., mirror heaters, battery box heaters, fuel tank heaters) check their operation.
- *Wipers and Washers* – Make sure the windshield wiper blades are in good condition. Make sure the wiper blades press against the windshield hard enough to wipe the

window clean. Otherwise they may not sweep off snow properly. Make sure the windshield washer works and there is washing fluid contained in the washer reservoir. Use windshield washer antifreeze to prevent freezing of the washer liquid. If you can't see well enough while driving, stop safely and fix the problem.

- *Tires* – Make sure you have enough tread on your tires. The drive tires must provide traction to push the rig over wet pavement and through snow. The steering tires must have traction to steer the vehicle. Enough tread is especially important in winter conditions. You should have at least 4/32 inch tread depth in every major groove on front wheels and at least 2/32 inch on other wheels. More would be better. Use a gauge to determine if you have enough tread for safe driving.
- *Tire Chains* – You may find yourself in conditions where you can't drive without chains, even to get to a place of safety. Carry the right number of chains and extra cross links. Make sure they will fit your drive tires. Check the chains for broken hooks, worn or broken cross-links, and bent or broken side chains. Learn how to put the chains on before you need to do it.
- *Lights and Reflectors* – Make sure the lights and reflectors are clean. Lights and reflectors are especially important during bad weather. Check from time to time during bad weather to make sure they are clean and working right.
- *Hand Holds, Steps and Deck Plates* – Remove all ice and snow from hand holds, steps and deck plates which you must use to enter the cab or to move about the vehicle. This will reduce the danger of slipping.
- *Radiator Shutters and Winter Front* – Remove ice from the radiator shutters. Make sure the winter front is not closed too tightly. If the shutters freeze shut or the winter front is closed too much, the engine may overheat and stop.
- *Exhaust System* – Exhaust system leaks are especially dangerous when cab ventilation may be poor (windows rolled up, etc.) Loose connections could permit poisonous carbon monoxide to lead into your vehicle. Carbon monoxide gas will cause you to be sleepy. Large amounts of carbon monoxide can kill you. Check the exhaust system for loose parts and for sounds and signs of leaks.

## Driving in Very Hot Weather

Do a normal pre-trip inspection by paying special attention to the following items:

- *Tires* – Check the tire mounting and air pressure. Inspect the tires every two hours or every 100 miles when driving in very hot weather. Air pressure increases with temperature. Do not let air out or the pressure will be too low when the tires cool off. If a tire is too hot to touch, remain stopped until the tire cools off. Otherwise, the tire may blow out or catch fire. Pay special attention to recapped or re-treaded tires. Under high temperatures the tread may separate from the body of the tire.
- *Engine oil* – The engine oil helps keep the engine cool, as well as lubricating it. Make sure there is enough engine oil. If you have an oil temperature gauge, make sure the temperature is within the proper range while you are driving.
- *Engine coolant* – Before starting out, make sure the engine cooling system has enough water and antifreeze according to the engine manufacturer's directions. (Antifreeze helps the engine under hot conditions as well as cold conditions.) When driving, check the water temperature or coolant temperature gauge from time to time. Make sure that it remains in the normal range. If the gauge goes above the highest safe temperature, there may be something wrong that could lead to engine failure and possibly fire. Stop driving as soon as safely possible and try to find out what is wrong.

Some vehicles have sight glasses or see-through coolant overflow containers or coolant recovery containers. These permit you to check the coolant level while the engine is hot. If the container is not part of the pressurized system, the cap can be safely removed and coolant added even when the engine is at operating temperature. If the engine is overheating, never remove the radiator cap or any part of the pressurized system until the system has cooled. Steam and boiling water can spray under pressure and cause severe burns. If you can touch the radiator cap with your bare hand, it is probably cool enough to open.

If coolant has to be added to a system without a recovery tank or overflow tank, follow these steps:

- ❖ Shut engine off.
  - ❖ Wait until engine has cooled.
  - ❖ Protect hands (use gloves or a thick cloth).
  - ❖ Turn radiator cap slowly to the first stop, which releases the pressure seal.
  - ❖ Step back while pressure is released from cooling system.
  - ❖ When all pressure has been released, press down on the cap and turn it further to remove it.
  - ❖ Visually check level of coolant and add more coolant if necessary.
  - ❖ Replace cap and turn all the way to the closed position.
- *Engine belts* – Learn how to check V-belt tightness on your vehicle by pressing on the belts. Loose belts will not turn the water pump and/or fan properly. This will result in overheating. Also check belts for cracking or other signs of wear.
  - *Hoses* – Make sure coolant hoses are in good condition. A broken hose while driving can lead to engine failure and fire.
  - *Watch for bleeding tar* – Tar in the road pavement frequently rises to the surface in very hot weather. Spots where tar “bleeds” to the surface are very slippery.
  - *Go slow enough to prevent overheating* – High speeds create more heat for tires and engine. In desert conditions the heat may build up to the point where it is dangerous. The heat will increase chances of tire failure, or fire and engine failure.

#### TEST YOUR KNOWLEDGE

1. You should use low beams whenever you can. True or False?
2. What should you do before you drive if you are drowsy?
3. What effects can wet brakes cause? How can you avoid these problems?
4. You should let air out of hot tires so the pressure goes back to normal. True or False?
5. You can safely remove the radiator cap as long as the engine isn't overheated. True or False?

## Seeing Hazards

### Importance of Seeing Hazards

- *What is a Hazard?* A hazard is defined as an unavoidable danger or risk (such as another driver, bicyclist, pedestrian, or road debris). Tourists can be hazards because they may drive slowly and make sudden stops or lane changes.
- *Seeing Hazards Lets You Be Prepared* – You will have more time to act if you see hazards before they become emergencies. In the example above, you might make a lane change or slow down to prevent a crash if the car suddenly cuts in front of you. Seeing this hazard gives you time to check your mirror and signal a lane change. Being prepared reduces the danger. A driver who did not see the hazard until the slow car pulled back on the highway in front of him would have to do something very suddenly.
- *Learning to See Hazards* – There are often clues that will help you see hazards. The more you drive, the better you can get at seeing hazards. This section will talk about hazards that you should be aware of.

### Hazardous Roads

Slow down and be very careful if you see any of the following road hazards:

- *Work Zones* – Construction zones on the highway could be considered a potential hazard. You may encounter narrowed lanes, obstacles, and uneven surfaces. Drive slowly and carefully through work zones and watch for sharp pavement drop-offs. Use your 4-way flashers or brake lights to warn drivers behind you when appropriate.
- *Uneven Road Shoulder* – Pavement may drop near the edge of the road. Steering may be difficult if you drive off the edge of the road and are forced to take corrective action. Driving too close to the edge may also cause your vehicle to tilt, making the top of your trailer hit roadside objects such as tree limbs or signs.
- *Road Debris* – Things that have fallen onto the road could cause damage to your tires and wheel rims. Debris can harm electrical and brake lines, or if caught between dual tires, could cause severe damage. It is important to remain alert for objects of all sorts, so you can see them early enough to take the appropriate action.
- *Off ramps/On ramps* – Freeway and turnpike exits can be particularly dangerous for commercial vehicles. Off ramps and on ramps often have speed limit signs posted. Remember, these speeds may be safe for automobiles but may not be safe for larger vehicles or heavily loaded vehicles. Exits that go downhill and turn at the same time can be especially dangerous. You should slow down to a safe speed *before* the curve. The downgrade makes it difficult to reduce speed, and braking and turning at the same time can be a dangerous practice.

### Drivers Who Are Hazards

In order to protect yourself and others, you must know when other drivers may do something hazardous. Some clues to this type of hazard are discussed below.

### Blocked Vision

People who can't see others are a very dangerous hazard. Be alert of drivers whose vision is blocked. Vans, loaded station wagons, and cars with the rear window blocked are examples. Rental trucks should be watched carefully. Their drivers are often not used to the limited vision to the sides and rear of the truck. In winter, vehicles with frosted, ice covered, or snow covered windows are also hazards.

### Vehicles may be partly hidden by blind intersections or alleys

If you only can see the rear or front end of a vehicle but not the driver, then he or she can't see you. Be alert because he/she may back out of an alley into your lane. Always be prepared to stop.

### Delivery trucks can present a hazard

Packages or vehicle doors often block the driver's vision. Drivers of step vans, postal vehicles, and local delivery vehicles often are in a hurry and may suddenly step out of their vehicle into the traffic lane.

### Parked vehicles can be hazards

When vehicles are parked, people may start to get out, or they may suddenly start up and drive into your way. Watch for movement inside the vehicle itself that shows people are inside. Watch brake lights or backup lights, exhaust, and other clues that a driver is about to move.

### Be careful of a stopped bus

Passengers may cross in front of, or behind, the bus and they often can't see you.

### Pedestrians and bicyclist can also be hazards

Walkers, joggers, and bicyclists may be on the road with their back to the traffic, so they can't see you. Sometimes they wear portable stereos with head sets, so they can't hear you, either. This can be dangerous. On rainy days, pedestrians may not see you because of hats or umbrellas. They may be hurrying to get out of the rain and may not pay attention to the traffic.

## **Emergencies**

Traffic emergencies occur when two vehicles are about to collide. Vehicle emergencies occur when tires, brakes, or other critical parts fail. Following the safety practices in this manual can help prevent emergencies. But, if an emergency does happen, your chances of avoiding a crash depend upon how well you take action. Actions you can take are discussed below.

### **Tire Failure**

There are four important things that safe drivers do to handle a tire failure safely:

- Be aware that a tire has failed.
- Hold the steering wheel firmly.

- Stay off the brake.
- After stopping, check all the tires.

### Recognize Tire Failure

Quickly knowing you have a tire failure will let you have more time to react. Having just a few seconds to remember what you're supposed to do can help you. The major signs of tire failure are:

*Sound* – The loud “bang” of a blowout is an easily recognized sign. Because it can take a few seconds for your vehicle to react, you might think it was some other vehicle. But any time you hear a tire blow, you'd be safest to assume it was yours.

*Vibration* – If the vehicle thumps or vibrates heavily, it may be a sign that one of the tires has gone flat. With a rear tire, that may be the only sign you get.

*Feel* – If the steering feels “heavy,” it is probably a sign that one of the front tires has failed. Sometimes, failure of a rear tire will cause the vehicle to slide back and forth or “fishtail.” However, dual rear tires usually prevent this.

Any of these signs is a warning of possible tire failure. You should do the following:

*Hold the Steering Wheel Firmly* – If a front tire fails, it can twist the steering wheel out of your hand. The only way to prevent this is to keep a firm grip on the steering wheel with both hands at all times.

*Stay Off the Brake* – It's natural to want to brake in an emergency. However, braking when a tire has failed could cause loss of control. Unless you're about to run into something, stay off the brake until the vehicle has slowed down. Then brake very gently, pull off the road, and stop.

*Check the Tires* – After you've come to a stop, get out and check all the tires. Do this even if the vehicle seems to be handling all right. If one of your dual tires goes flat, the only way you may know it is by getting out and looking at it.

### **Skid Control and Recovery**

A skid happens whenever the tires lose their grip on the road. This is caused in one of four ways:

*Over braking* – Braking too hard (over braking) will lock up the wheels. Skids also can occur when using the speed retarder when the road is slippery.

*Over steering* – Turning more sharply than the vehicle can safely turn.

*Over acceleration* – Supplying too much power to the drive wheels, causing them to spin.

*Driving too fast* – Most serious skids result from driving too fast for road conditions. Drivers who adjust their driving to conditions don't over accelerate and don't have to over brake or over steer from too much speed.

### Drive-Wheel Skids

By far, the most common skid is one in which the rear wheels lose traction through excessive braking or acceleration. Skids caused by acceleration usually happen on ice or snow. Taking your foot off the accelerator can easily stop them. (If it is very slippery, push the clutch in. Otherwise the engine can keep the wheels from rolling freely and regaining traction.)

Rear-wheel braking skids occur when the rear drive wheels lock. Because locked wheels have less traction than rolling wheels, the rear wheels usually slide sideways in an attempt to "catch up" with the front wheels. In a bus or straight truck, the vehicle will slide sideways in a "spin out." With vehicles towing trailers, a drive-wheel skid can let the trailer push the towing vehicle sideways, causing a sudden jackknife.

### Correcting a Drive-Wheel Braking Skid

Do the following to correct a drive-wheel braking skid:

*Stop braking* – This will let the rear wheels roll again and keep the rear wheels from sliding any further. If on ice, push in the clutch to let the wheels turn freely.

*Turn quickly* – When a vehicle begins to slide sideways, quickly steer in the direction you want the vehicle to go – down the road. You must turn the wheel quickly.

*Counter steer* – As a vehicle turns back on course, it has a tendency to keep right on turning. Unless you turn the steering wheel quickly the other way, you may find yourself skidding in the opposite direction.

Learning to stay off the brake, turn the steering wheel quickly, push in the clutch and counter steer in a skid takes a lot of practice. The best place to get this practice is on a large driving range or "skid pad."

### Front-Wheel Skids

Most front-wheel skids are caused by driving too fast for conditions. Other causes are lack of tread on the front tires and cargo loaded so not enough weight is on the front axle. In a front-wheel skid, the front end tends to go in a straight line regardless of how much you turn the steering wheel. On a very slippery surface, you may not be able to steer around a curve or turn.

When a front-wheel skid occurs, the only way to stop the skid is to let the vehicle slow down. Stop turning and/or braking so hard. Slow down as quickly as possible without skidding.

## TEST YOUR KNOWLEDGE

1. Stopping is not always the safest thing to do in an emergency. True or False
2. What are some advantages of going right instead of left around an obstacle?
3. What is an “escape ramp”?
4. If a tire blows out, you should put the brakes on hard to stop quickly. True or False?

### **Accident Procedures**

When you're in an accident and not seriously hurt, you need to act to prevent further damage or injury. The basic steps to be taken at any accident are to:

#### Protect the Area

The first thing to do at an accident scene is to keep another accident from happening at the same spot. To protect the accident area:

- If your vehicle is involved in the accident, try to get it to the side of the road. This will help prevent another accident and allow traffic to move.
- If you're stopping to help, park away from the accident. The area immediately around the accident will be needed for emergency vehicles.
- Put on your flashers.
- Set out reflective triangles to warn other traffic. Make sure they can be seen by other drivers in time for them to avoid the accident.

#### Notify Authorities

If you have a CB, put out a call over the emergency channel, or if you have a cell phone, dial 9-1-1 before you get out of your vehicle. If not, wait until after the accident scene has been properly protected, then phone or send someone to phone the police. Try to determine where you are so you can give the exact location.

#### Care for Injured

If a qualified person is at the accident and helping the injured, stay out of the way unless asked to assist. Otherwise, do the best you can to help any injured parties. Here are some simple steps to follow in giving assistance:

- Don't move a severely injured person unless the danger of fire or passing traffic makes it necessary.
- Stop heavy bleeding by applying direct pressure to the wound.
- Keep the injured person warm.

### **Fires**

Truck fires can cause damage and injury. Learn the cause of fires and how to prevent them. Know what to do to extinguish fires.



Causes of Fire – The following are some causes of vehicle fires:

- *After accidents* – Spilled fuel, improper use of flares.
- *Tires* – Under-inflated tires and duals that touch.
- *Electrical system* – Short circuits due to damaged insulation, loose connections.
- *Fuel* – Driver smoking, improper fueling, loose fuel connections.
- *Cargo* – Flammable cargo, improperly sealed or loaded, poor ventilation.

Fire Prevention - Pay attention to the following:

- *Pre-trip inspection* – Make a complete inspection of the electrical, fuel, and exhaust systems, tires and cargo.
- *En-route inspection* – Check the tires, wheels, and truck body for signs of heat whenever you stop during a trip.
- *Follow safe procedures* – Follow correct safety procedures for fueling the vehicle, using brakes, handling flares, and other activities that can cause a fire.
- *Monitoring* – Check the instruments and gauges often for signals of overheating, and use the mirrors to look for signs of smoke from the tires or the vehicle.
- *Caution* – Use normal caution in handling anything flammable.

### Fire Fighting

Knowing how to fight fires is important. Fires have been made worse by drivers who didn't know what to do. Here are some procedures to follow in case of fires:

- *Pull off the road* – The first step is to get the vehicle off the road and stop. In doing so:
  - Park in an open area, away from buildings, trees, brush, other vehicles or anything that might catch fire.
  - Don't pull into a service station!
  - Use your CB radio if you have one to notify the police of your problem and your location; or
  - If you have a cell phone, dial 9-1-1 for assistance.
- *Keep the fire from spreading* – Before trying to put out the fire, make sure that it doesn't spread any further.
  - With an engine fire, turn off the engine as soon as you can. Don't open the hood if you can avoid it. Shoot extinguishers through louvers, radiator, or from the underside of the vehicle.
  - For a cargo fire in a van or box trailer, keep the door shut, especially if your cargo contains hazardous materials. Opening the van doors will supply the fire with oxygen and can cause it to burn very fast.
- *Use the right fire extinguisher*
  - The B:C type fire extinguisher is designed to work on electrical fires and burning liquids.
  - The A:B:C type is designed to work on burning wood, paper or cloth, but don't use water on an electrical fire (you could get shocked) or a gasoline fire (it will spread the flames).
  - A burning tire must be cooled. Lots of water may be required. If you're not sure what to use, especially on a hazardous materials fire, wait for qualified fire fighters.

- *Extinguishing the fire* – Here are some rules to follow in putting out a fire:
  - Know how the fire extinguisher works before a fire happens. Study the instructions printed on the extinguisher before you need it.
  - When using the extinguisher, stay as far away from the fire as possible.
  - Aim at the source or base of the fire, not up in the flames. Position yourself upwind. Let the wind carry the extinguisher to the fire rather than carrying the flames to you.
  - Continue until whatever was burning has been cooled. Absence of smoke or flame does not mean the fire is completely out or cannot restart.
  - Only try to extinguish a fire if you know what you are doing and it is safe to do so.

#### TEST YOUR KNOWLEDGE

1. What are some things to do at an accident scene to prevent another accident?
2. Name two causes of tire fires.
3. What kinds of fires is a B:C extinguisher **not** good for?
4. When using your extinguisher, should you get as close as possible to the fire?
5. Name some causes of vehicle fires.

## Staying Alert and Fit to Drive

Driving a vehicle for long hours is tiring. Even the best of drivers will become less alert. However, there are things that good drivers can do to help stay alert and safe. Here are a few suggestions:

### Get enough sleep

Leaving on a long trip when you are already tired is dangerous. If you have a long trip scheduled, make sure you get good sleep before you go. Most people require 7 to 8 hours of sleep every 24 hours.

### Schedule trips safely

Your body gets used to sleeping during certain hours of a day. If you are driving during those hours, you will be less alert. If possible, try to schedule trips for the hours you are normally awake. Many heavy motor vehicle accidents occur between midnight and 6 a.m. Tired drivers can easily fall asleep at these times, especially if they don't regularly drive at those hours. Trying to push on and finish a long trip at these times can be very dangerous.

### Avoid medication

Many medicines can make you drowsy. Those medicines have label warnings against operating vehicles or machinery. The most common is an ordinary cold pill. If you have to drive with a cold, you are better off suffering from the cold symptoms than from the effects of the medicine.

## Keep cool

A hot, poorly ventilated cab can make you sleepy. Keep the window or vent cracked, or use the air conditioner if you have one.

## Take breaks

Short breaks can help you stay alert, but the time to take them is *before* you are drowsy. Stop often. Walk around and inspect your vehicle. It may help to do some physical exercise.

## When You do Become Sleepy

When you are sleepy, trying to “push on” is far more dangerous than most drivers think. It is a major cause of fatal accidents. Here are some rules to follow:

- *Stop to sleep* – When your body needs sleep, sleep is the only thing that will work. If you have to make a stop anyway, make it whenever you feel the first signs of sleepiness, even if it is earlier than you planned. By getting up a little earlier the next day, you can keep on schedule without the danger of driving while you are not alert.
- *Take a nap* – If you can't stop for the night, at least pull off the road and take a nap. A half-hour nap will do more to overcome fatigue than a half-hour coffee stop.
- *Avoid drugs* – There are no drugs that can overcome being tired. While they may keep you awake for a while, they won't make you alert. And eventually, you'll be even more tired than if you hadn't taken them at all. Sleep is the only thing that can overcome fatigue.

## Alcohol and Driving

Drinking alcohol and then driving is a very serious problem. People who drink alcohol are involved in traffic accidents resulting in over 20,000 deaths every year. You should know:

- How alcohol works in the human body
- How it affects driving
- Laws regarding drinking and driving
- Legal, financial, and safety risks of drinking and driving

## The truth about alcohol

There are many dangerous ideas about the use of alcohol. The driver who believes in these wrong ideas will be more likely to get into trouble. Here are some examples:

### **False**

Alcohol increases the ability to drive.

Some people can drink a lot and not seem affected by it.

### **True**

Alcohol is a drug that will make you less alert and reduce your ability to drive safely.

Everyone who drinks is affected by alcohol.

If you eat a lot first, you won't get drunk.

Coffee and a little fresh air will help sober you up.

Stick with beer - it's not as strong as wine or whiskey.

Food will not keep you from getting drunk.

Only time will help a drinker sober up - other methods just don't work.

A few beers are the same as a few shots of whiskey or a few glasses of wine.

### What is a drink?

It is the alcohol in drinks that impairs human performance. It doesn't make any difference whether that alcohol comes from "a couple of beers," from two glasses of wine, or two shots of hard liquor. All of the following drinks contain the same amount of alcohol:

- A 12-ounce glass of 5% beer
- A 5-ounce glass of 12% wine
- A 1½-ounce shot of 80-proof liquor

### How alcohol works

Alcohol goes directly from the stomach into the blood stream. A drinker can control the amount of alcohol that he or she consumes by having fewer drinks or none. However, the drinker cannot control how fast the body gets rid of alcohol. If you have drinks faster than the body can get rid of them, you will have more alcohol in your body, and your driving will be more affected. The amount of alcohol in your body is commonly measured by the Blood Alcohol Concentration (BAC).

### What determines Blood Alcohol Concentration?

BAC is determined by the amount of alcohol you drink (more alcohol means higher BAC), how fast you drink (faster drinking means higher BAC), and your weight (a small person doesn't have to drink as much to reach the same BAC).

### Alcohol and the brain

Alcohol affects more and more of the brain as BAC builds up. The first part of the brain affected controls judgment and self-control, which are necessary for safe driving. One of the bad things about this is it can keep drinkers from knowing they are getting drunk.

As blood alcohol concentration continues to build up, muscle control, vision, and coordination are affected more and more. Eventually, a person will pass out.

*How alcohol affects driving* – All drivers are affected by drinking alcohol. Alcohol affects judgment, vision, coordination, and reaction time. It causes serious driving errors, such as:

- Increased reaction time to hazards
- Driving too fast or too slow
- Driving in the wrong lane

- Running over the curb
- Weaving
- Straddling lanes
- Quick jerky starts
- Not signaling, failure to use lights
- Running stop signs and red lights
- Improper passing

These effects mean increased chances of a crash and chances of losing your driver's license. Accident statistics show that the chance of a crash is much greater for drivers who have been drinking than for drivers who were not.

### Other drugs

Besides alcohol, other legal and illegal drugs are being used more often. Laws prohibit possession or use of many drugs. They prohibit being under the influence of any "controlled substance" such as Amphetamines (including "pep pills" and "bennies"), narcotics or any other substance that can make the driver unsafe. This could include a variety of prescriptions and over-the-counter drugs (cold medicines) that may make the driver sleepy or otherwise affect safe driving ability. However, possession and use of a drug given to a driver by a doctor is permitted if the doctor informs the driver that it will not affect safe driving ability.

Pay attention to warning labels of legitimate drugs and medicines and to doctor's orders regarding possible effects. Stay away from illegal drugs. Don't use any drug that hides fatigue. The only cure for fatigue is rest. Alcohol can make the effects of other drugs much worse. The safest rule is, don't mix drugs with driving at all.

Use of drugs can lead to traffic accidents, resulting in death, injury, and property damage. Furthermore, it can lead to arrest, fines, and jail sentences. It can also mean the end of a person's driving privilege.

### Illness

Once in a while, you may become so ill that you cannot operate a motor vehicle safely. If this happens to you, you must not drive. However, in case of an emergency, you may drive to the nearest place where you can safely stop.

# Section 2 - Transporting Cargo Safely

## Inspecting and Securing Cargo

This section tells you about cargo safety. All drivers must understand some basic cargo safety rules to get a Class A or B license. If you load cargo wrong, it can be a danger to others and to yourself. Cargo that is not loaded or secured properly can cause other highway users to hit or be hit by loose cargo. Loose cargo can hurt you or passengers during a quick stop or crash.

### Inspecting your cargo

As part of your pre-trip inspection, check for overloads, poorly balanced weight, and cargo that is not secured correctly. Also check that all outside storage compartment doors are latched securely or locked.

Inspect the cargo and its securing devices again within 50 miles after beginning a trip and make any adjustments needed. Inspect again after you have driven for 3 hours or 150 miles, and after every break you take during the drive.

### Weight and balance

It is important to know the weight and balance of your loaded vehicle. Overloading can have bad effects on steering, braking, and speed control. Overloaded vehicles have to go very slowly on upgrades. Worse, they may gain too much speed on downgrades. Stopping distance increases and brakes can fail when forced to work too hard.

You are responsible to make certain your vehicle is not overloaded. Here are some definitions of weight you should know:

- *Gross vehicle weight (GVW)* – The total weight of a single vehicle plus its load.
- *Gross combination weight (GCW)* – The total weight of a powered unit plus trailer(s) plus the cargo.
- *Gross combination weight rating (GCWR)* – The weight specified by the manufacturer of a vehicle as the combined loaded weight of that vehicle and a trailing vehicle.
- *Axle weight* – The weight transmitted to the ground by one axle or one set of axles.
- *Tire load* – The maximum safe weight a tire can carry at a specified pressure. This rating is stated on the side of each tire.
- *Suspension systems* – Suspension systems have a manufacturer's weight capacity rating.
- *Coupling device capacity* – Coupling devices are rated for the maximum weight they can pull and/or carry.
- *Legal weight limits* – You must keep weights within legal limits. States have maximums for GVWs, GCWs, and axle weights. Often, maximum axle weights are set by a bridge formula. A bridge formula permits less maximum axle weight for axles that are closer together. This is to prevent overloading bridges and roadways.

Don't be top-heavy. The height of the vehicle's center of gravity is very important for safe handling. A high center of gravity (cargo piled up high or heavy cargo on top) means it is easier to turn over. It is very important to distribute the cargo so it is as low as possible. Put the heaviest parts of the cargo under the lightest parts or in the lower storage compartments. Rolling over is also more likely in curves, if you have to swerve to avoid a hazard, or turns. Drive slowly around turns and use a safe speed in curves.

Balance the weight. When loading cargo, keep the load balanced in the cargo area. Poor weight balance can make vehicle handling unsafe. Too much weight on the steering axle can make steering difficult and cause damage to the steering axle and tires. Under-loaded front axles (caused by shifting weight too far to the rear) can make the steering axle weight too light to steer safely. Also, too little weight on the driving axles can cause poor traction. The drive wheels may spin easily. During bad weather, the truck or RV may not be able to keep going.

## Section 3 - Air Brakes

This section tells you about air brakes. You need this information for safe operation of air brakes used on trucks, RVs, and buses. If you want to pull a trailer with air brakes, you will also need to read Section 4: Combination Vehicles.

Air brakes use compressed air to make the brakes work. You can apply all the braking force you need to each of the wheels of a heavy vehicle, even units pulling 2 or 3 trailers. Air brakes are a safe way of stopping large vehicles if the brakes are well maintained and used right. However, you must know more about air brakes than you need to know with the simple brake systems used on light vehicles. Therefore, it is important for you to study this section.

Air brake systems are three braking systems combined: the service brake system, the parking brake system, and the emergency brake system.

The service brake system applies and releases the brakes when you use the brake pedal during normal driving.

The parking brake system applies and releases the parking brakes when you use the parking brake control.

The emergency brake system uses parts of the service and parking brake systems to stop the vehicle in the event of a brake system failure.

### The Parts of an Air Brake System

There are many parts to an air brake system. You should know about the parts discussed here.

#### Air compressor

The air compressor pumps air into the air storage tanks (reservoirs). The air compressor is connected to the engine through gears or a V-belt. The compressor may be air cooled or may be cooled by the engine cooling system. It may have its own oil supply or be lubricated by engine oil. If the compressor has its own oil supply, check the oil level before driving.

#### Air compressor governor

The governor controls when the air compressor will pump air into the air storage tanks. When air tank pressure rises to the “cut-out” level (around 125 pounds per square inch or “psi”), the governor stops the compressor from pumping air. When the tank pressure falls into the “cut-in” pressure (around 100 psi) the governor allows the compressor to start pumping again.

#### Air storage tanks

Air storage tanks are used to hold compressed air. The number and size of air tanks varies among vehicles. The tanks will hold enough air to allow the brakes to be used several times, even if the compressor stops working.



## Air tank drains

Compressed air usually has some water and some compressor oil in it that is bad for the air brake system. For example, the water can freeze in cold weather and cause brake failure. The water and oil tend to collect in the bottom of the air tank. Therefore, each air tank is equipped with a drain valve in the bottom. There are two types:

- Manual – This is operated by turning a quarter turn or by pulling a cable. You must drain the tanks yourself at the end of each day of driving; and
- Automatic – The water and oil is automatically expelled. Airtanks may be equipped for manual draining as well. The automatic types are available with electric heating devices. This helps prevent freeze up of the automatic drain in cold weather.

Figure 3-1  
Manual Drain Valve

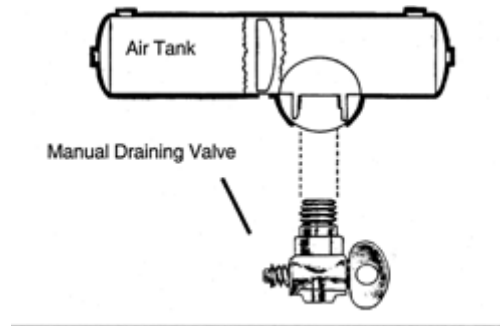

## Alcohol evaporator

Some air brake systems have an alcohol evaporator to put alcohol into the air system. This helps to reduce the risk of ice in the air brake valves and other parts during cold weather. Ice inside the system can make the brakes stop working.

Check the alcohol container and fill up as necessary every day during cold weather. Daily air tank drainage is still needed to rid the system of water and oil (unless the system has automatic drain valves).

## Safety valve

A safety relief valve is installed in the first tank the air compressor pumps air to. The safety valve protects the tank and the rest of the system from too much pressure. The valve is usually set to open at 150 psi. If the safety valve releases air, something is wrong. Have the fault fixed by a mechanic.

## The brake pedal

You put on the brakes by pushing down on the brake pedal. Pushing the pedal down harder applies more air pressure. Letting up on the brake pedal reduces the air pressure and releases the brakes. Releasing the brakes lets some compressed air go out of the system, so the air pressure in the tanks is reduced. It must be made up by the air compressor. Pressing and releasing the pedal unnecessarily can let air out faster than the compressor can replace it. If the pressure goes too low, the brakes won't work.

When you push the brake pedal down, two forces push back against your foot. One force comes from a spring. The second force comes from the air pressure going to the brakes. This lets you feel how much air pressure is being applied to the brakes.

- *S-Cam Brakes* – When you push the brake pedal, air is let into each brake chamber. Air pressure pushes the rod out, moving the slack adjuster, thus twisting the brake cam shaft. This turns the s-cam (so called because it is shaped like the letter “s”). The s-cam forces the brake shoes away from one another and presses them against the inside of the brake drum, and a spring pulls the brake shoes away from the drum, allowing the wheels to roll freely again.

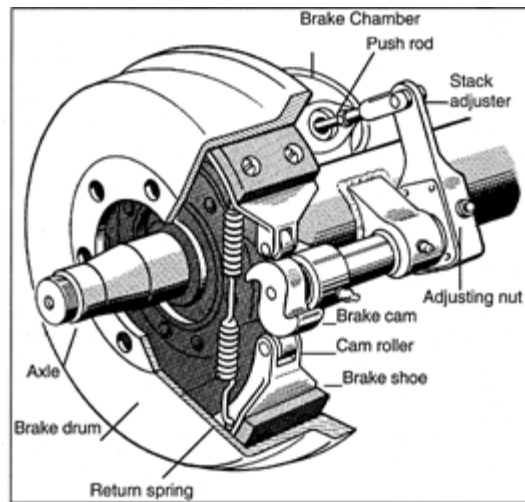

Figure  
S-cam Air Brake

3-2

- *Wedge Brakes* – In this type of brake, the brake chamber push-rod pushes a wedge directly between the ends of two brake shoes. This shoves them apart and against the inside of the brake drum. Wedge brakes may have a single brake chamber or two brake chambers, pushing wedges in at both ends of the brake shoes. Wedge type brakes may be self-adjusting or may require manual adjustment.

### Supply pressure gauges

All air-braked vehicles have a pressure gauge connected to the air tank. If the vehicle has a dual air brake system, there will be a gauge for each half of the system (or a single gauge with two needles). Dual systems will be discussed later. These gauges tell you how much pressure is in the air tanks.

### Application pressure gauge

The gauge shows how much air pressure you are applying to the brakes. This gauge is not on all vehicles. When going down steep grades, increasing application pressure to hold the same speed means the brakes are fading. You should slow down and use a lower gear. The need for increased pressure can also be caused by brakes being out of adjustment, air leaks, or mechanical problems.

### Low air pressure warning

A low air pressure warning signal is required on vehicles with air brakes. A warning signal you can see must come on before the air pressure in the tanks falls below 60 psi, or one-half the compressor governor cut-out pressure on older vehicle(s). The warning signal is usually a red light. A buzzer may also come on.

Another type of warning is the “wig-wag.” This device drops a mechanical arm into your view when the pressure in the system drops below 60 psi. An automatic wig-wag will rise out of your view when the pressure in the system goes above 60 psi. The manual reset type must be placed in the “out-of-view” position manually. It will not stay in place until the pressure in the system is above 60 psi.

On large buses, it is common for the low pressure warning devices to signal at 80-85 psi.

### Stop light switch

Drivers behind you must be warned when you apply your brakes. The air brake system does this with an electric switch that works by air pressure. The switch turns on the brake lights when you apply the air brakes.

### Front brake limiting valve

Some older vehicles (made before 1975) have a front brake limiting valve and a control in the cab. The control is usually marked “normal” and “slippery.” When you put the control in the “slippery” position, the limiting valve cuts the “normal” air pressure to the front brakes by half. Limiting valves were used to reduce the chance of the front wheels skidding on slippery surfaces. However, they actually reduce the stopping power of the vehicle. Front wheel braking is good under all conditions. Tests have shown front wheel skids from braking are not likely, even on ice. Make sure the control is in the “normal” position to have normal stopping power.

Many vehicles have automatic front wheel limiting valves. They reduce the air to the front brakes except when the brakes are put on very hard (60 psi or more application pressure). These valves cannot be controlled by the driver.

### Spring brakes

All trucks, RVs, and buses must be equipped with emergency brakes and parking brakes. They must be held on by mechanical force (because air pressure can eventually leak away). Spring brakes are usually used to meet these needs. When driving, powerful springs are held back by air pressure. If the air pressure is removed, the springs put on the brakes. A parking brake control in the cab allows the driver to let the air out of the spring brakes. This lets the springs put the brakes on. A leak in the air brake system that causes all the air to be lost will also cause the springs to put on the brakes.

Spring brakes will come fully on when air pressure drops to a range of 20 to 45 psi (typically 20 to 30 psi). Do not wait for the brakes to come on automatically. When the low air pressure warning light and buzzer first come on, bring the vehicle to a safe stop right away, while you can still control the brakes.

The braking power of spring brakes depends on the brakes being in adjustment. If the brakes are not adjusted right, neither the regular brakes nor the emergency parking brakes will work right.

### Parking brake controls

In newer vehicles with air brakes, you put on the parking brakes using a diamond shaped, yellow, push-pull control knob. You pull the knob out to put the parking brakes (spring brakes) on, and push it in to release them. On older vehicles, the parking brakes may be controlled by a lever. Use the parking brakes whenever you park.

**Caution:** Never push the brake pedal down when the spring brakes are on. If you do, the brakes could be damaged by the combined forces of the springs and the air pressure. Many brake systems are designed so this will not happen. Not all systems are set up that way, and those that are may not always work. It is much better to develop the habit of not pushing the brake pedal down when the spring brakes are on.

### Modulating control valves

In some vehicles, a control handle on the dashboard may be used to apply the spring brakes gradually. This is called a modulating valve. It is spring loaded so you have a feel for the braking action. The more you move the control lever, the harder the spring brakes come on. They work this way so you can control the spring brakes if the service brakes fail. When parking a vehicle with a modulating control valve, move the lever as far as it will go and hold it in place with the locking device.

### Dual parking control valves

When main air pressure is lost, the spring brakes come on. Some vehicles, such as buses, have a separate air tank that can be used to release the spring brakes. This is so you can move the vehicle in an emergency. One of the valves is a push-pull type and is used to put on the spring brakes for parking. The other valve is spring loaded in the "out" position. When you push the control in, air from the separate air tank releases the spring break so you can move. When you release the button, the spring brakes come on again. There is only enough air in the separate tank to do this a few times. Therefore, plan carefully when moving. Otherwise, you may be stopped in a dangerous location when the separate air supply runs out.

#### TEST YOUR KNOWLEDGE

1. Why must air tanks be drained?
2. What is a supply pressure gauge used for?
3. All vehicles with air brakes must have a low air pressure warning signal. True or False?
4. What are spring brakes?
5. Front wheel brakes are good under all conditions. True or False?

## Dual Air Brakes

Most newer heavy-duty vehicles use dual air brake systems for safety. A dual air brake system has two separate air brake systems that use a single set of brake controls. Each system has its

own set of brake controls. Each system has its own air tanks, hoses, lines, etc. One system typically operates the regular brakes on the rear axle or axles. The other system operates the regular brakes on the front axle (and possibly one rear axle). Both systems supply air to the trailer if there is one. The first system is called the “primary system.” The other is called the “secondary system.”

Before driving a vehicle with a dual air system, allow time for the air compressor to build up a minimum of 100 psi in both the primary and secondary systems. Watch the primary and secondary air pressure gauges or needles if the system has two needles in one gauge. Pay attention to the low air pressure warning light and buzzer. The warning light and buzzer should shut off when air pressure in both systems rises to a value set by the manufacturer. This value must be greater than 60 psi.

The warning light and buzzer should come on before the air pressure drops below 60 psi in either system. If this happens while driving, you should stop right away and safely park the vehicle. If one air system is very low on pressure, either the front or the rear brakes will not be operating fully. This means it will take you longer to stop. Bring the vehicle to a safe stop and have the air brakes system repaired.

## **Walk-Around Inspection**

Check Manual Slack Adjusters on S-cam brakes. Park on level ground and chock the wheels to prevent the vehicle from moving. Turn off the parking brakes so you can move the slack adjusters. Use gloves and pull hard on each slack adjuster that you can get to. If a slack adjuster moves more than about one inch where the push rod attaches to it, it probably needs adjustment. Adjust it or have it adjusted. Vehicles with too much brake slack can be very hard to stop. Out-of-adjustment brakes are the most common problem found in roadside inspections. Be safe; check the slack adjusters.

## **Final Air Brake Check**

### Test low-pressure warning signal

Shut the engine off when you have enough air pressure that the low-pressure warning signal is not on. Turn the electric power on and step on and off the brake pedal to reduce air tank pressure. The low air pressure warning signal must come on before the pressure drops to less than 60 psi in the air tank, or tank with the lowest air pressure, in dual air systems.

If the warning signal doesn't work, you could lose air pressure and you would not know it. This could cause sudden emergency braking in a single circuit air system. In dual systems, the stopping distance will be increased. Only limited braking can be done before the spring brakes come on.

### Check that the spring brakes come on automatically

Chock the wheels, release the parking brakes when you have enough air pressure to do it, and shut the engine off. Step on and off the brake pedal to reduce the air tank pressure. The “parking brake” knob should pop out when the air pressure falls to the manufacturer's specification, usually in a range between 20 and 40 psi. This causes the spring brakes to come on.

### Check rate of air pressure build-up

With the engine at operating RPM, the pressure should build from 85 to 100 psi within 45 seconds in dual air systems. If the vehicle has larger than minimum air tanks, the build-up time can be longer and still be safe. Check the manufacturer's specifications. In single air systems (pre 1975), typical requirements are pressure build-up from 50 to 90 psi within 3 minutes with the engine at an idle speed of 600 to 900 RPM.

If air pressure does not build up fast enough, your pressure may drop too low during driving, requiring an emergency stop. Don't drive until you get the problem fixed.

### Test air leakage rate

With a fully-charged air system, typically 125 psi, turn off the engine, release the service brake and time the air pressure drop. The loss rate should be less than 2 psi in one minute for single vehicles, less than 3 psi in one minute for combination vehicles. Then apply 90 psi or more with the brake pedal. After the initial pressure drop, if the air pressure falls more than 3 psi in one minute for single vehicles, more than 4 psi for combination vehicles, the air loss rate is too much. Check for air leaks and fix before driving the vehicle. Otherwise, you could lose your brakes while driving.

### Check air compressor governor cut-in and cut-out pressures

Pumping by the air compressor should start at about 100 psi and stop at about 125 psi. (Check the manufacturer's specifications.) Run the engine at a fast idle. The air governor should cut-out the air compressor at about the manufacturer's specified pressure. The air pressure shown by your gauge(s) will stop rising. With the engine idling, step on and off the brake to reduce the air tank pressure. The compressor should cut-in at about the manufacturer's specified cut-in pressure. The pressure should begin to rise.

If the air governor does not work as described, it may need to be fixed. A governor that does not work right may not keep enough air pressure for safe driving.

### Test parking brake

Stop the vehicle, put the parking brake on, and gently pull against it in a low gear to test that the parking brake will hold.

### Test service brakes

Wait for normal air pressure, release the parking brake, move the vehicle forward slowly (about 5 mph), and apply the brakes firmly using the brake pedal. Note any vehicle "pulling" to one side, unusual feel, or delayed stopping action.

## TEST YOUR KNOWLEDGE

1. What is a dual air brake system?
2. What are slack adjusters?
3. How can you check slack adjusters?
4. How can you test the low-pressure warning signal?
5. How can you check that the spring brakes come on automatically?
6. What are the maximum leakage rates?

## Using Air Brakes

### Normal stops

Push the brake pedal down. Control the pressure so the vehicle comes to a smooth safe stop. If you have a manual transmission, don't push the clutch in until the engine RPM is down close to idle. When stopped, select a starting gear.

### Emergency stops

You should brake so you can steer and so your vehicle stays in a straight line. Use one of the following two methods.

- *Control braking* – This method is also called “squeeze” braking. Put on the brakes as hard as you can without locking the wheels. Do not turn the steering wheel while doing this. If you need to make large steering adjustments or if you feel the wheels sliding, release the brakes. Brake again as soon as the tires get traction.
- *Stab braking* – Press on the brake pedal as hard as you can. Release the brakes when the wheels lock up and as soon as the wheels start rolling, put on the brakes fully again. It can take up to one second for the wheels to start rolling after you release the brakes. Make sure you stay off the brakes long enough to get the wheels rolling again. Otherwise the vehicle may not stay in a straight line.

### Stopping distance

We talked about stopping distance in Section 2 under “speed and stopping distance.” With air brakes there is an added delay: the time required for the brakes to work after the brake pedal is pushed. With hydraulic brakes, used on cars and light/medium trucks, the brakes work instantly. However, with air brakes, it takes a little time for the air to flow through the lines to the brakes – generally one-half second or more. Thus, the total stopping distance for vehicles with air brake systems is made up of four different factors: perception distance, reaction distance, brake lag distance, and effective braking distance.

The air brake lag distance at 55 mph on dry pavement adds about 32 feet. So at 55 mph for an average driver under good traction and brake conditions, the total stopping distance is over 300 feet. This is longer than a football field.

### Braking on downgrades

When you use the brakes, they get hot. Brakes can take a lot of heat. However, brakes will stop working if there is too much heat. Excessive heat is caused by trying to slow down from too high a speed too many times or too quickly. Brakes will fade when they get too hot. You will have to push harder on the pedal to get the same stopping force. They can fade so badly they will not slow you down.

It is always important for the brakes to be adjusted right. However, it is especially important when going down steep grades. In addition to proper slack adjustment, the air brake system should be balanced to give about the same braking at each of the wheels. Otherwise, some brakes will do more work than others. They will heat up and lose some of their stopping power. Brake balance can be tested and fixed by good air brake mechanics.

### Low air pressure warning

If the low air pressure warning comes on, stop and safely park your vehicle as soon as possible. There might be an air leak in the system. Controlled braking is possible only while enough air remains in the air tanks. The spring brakes will come on when the air pressure drops into the range 20 to 45 psi. A heavily loaded vehicle will take a long distance to stop because the spring brakes do not work on all axles. Lightly loaded vehicles or vehicles on slippery roads may skid out of control when the spring brakes come on. It is much safer while there is enough air in the tanks to use the foot brakes.

### Brake fading or failure

Brakes are designed so brake shoes or pads rub against the brake drum or disks to slow the vehicle. Braking creates heat, but brakes are designed to take a lot of heat. However, brakes can fade or fail from excessive heat caused by using them too much and not relying on the engine braking effect.

Excessive use of the service brakes results in overheating and leads to brake fade. Brake fade results from excessive heat causing chemical changes in the brake lining that reduce friction and also causes expansion of the brake drums. As the overheating drums expand, the brake shoes and linings have to move farther to contact the drums, and the force of this contact is also reduced. Continued overuse may increase brake fade until the vehicle cannot be slowed down or stopped at all.

Brakes can also fade because of improper adjustment. To safely control a vehicle, every brake must do its share of the work. If some brakes are out of adjustment, they will not be doing their share. The other brakes can overheat and fade, and there will not be sufficient braking available to control the vehicle(s). Brakes can get out of adjustment quickly, especially when they are hot. Therefore, brake adjustment must be checked frequently.

### Proper braking technique

The use of brakes on a long and/or steep downgrade is only a supplement to the braking effect of the engine. Once the vehicle is in the proper low gear, the following is the proper braking technique:

1. Apply the brakes just hard enough to feel a definite shutdown.
2. When your speed has been reduced to approximately 5 mph below your “safe” speed, release the brakes.
3. When your speed has increased to your “safe” speed, repeat steps 1 and 2.

*For example – If your “safe” speed is 40 mph, you would not apply the brakes until your speed reaches 40 mph. You now apply the brakes hard enough to gradually reduce your speed to 35 mph and then release the brakes. Repeat this as often as necessary until you have reached the end of the downgrade.*

### Parking brakes

Any time you park, use the parking brakes, except as noted below. Pull the parking brake control knob out to apply the parking brakes, push it in to release them. The control will be a



yellow, diamond shaped knob labeled “parking brakes” on newer vehicles. On older vehicles, it may be a round blue knob or some other shape (including a lever that swings from side to side or up and down).

Don't use the parking brakes if the brakes are very hot from just having come down a steep grade, or if the brakes are very wet in freezing temperatures. If they are used while they are very hot, they can be damaged by the heat. If they are used in freezing temperatures when the brakes are very wet, they can freeze so the vehicle cannot move. Use wheel chocks to hold the vehicle. Let hot brakes cool before using the parking brakes. If the brakes are wet, use the brakes lightly while driving in a low gear to heat and dry them.

If your vehicle does not have automatic air tank drains, drain your tanks at the end of each working day to remove moisture and oil. Otherwise the brakes could fail.

# Section 4 - Combination Vehicles

This section provides information needed to pass the tests for combination vehicles (tractor-trailer, doubles, triples, straight truck and trailer). The information is only to give you the minimum knowledge needed for driving common combination vehicles. This section covers driving combinations, coupling and uncoupling, and inspection combinations.

Combination vehicles are usually heavier, longer, and require more driving skills than single commercial vehicles. This means that drivers of combination vehicles need more knowledge and skill than drivers of single vehicles. In this section, we talk about some important safety factors that apply specifically to combination vehicles.

## Rollover risks

More than half of truck driver deaths in crashes are from truck rollovers. When more cargo is piled up in a truck, the “center of gravity” moves higher up from the road. The truck becomes easier to turn over. Fully loaded rigs are 10 times more likely to roll over in a crash than empty rigs.

Do the following two things to help prevent a rollover.

- Keep the cargo as close to the ground as possible, and go slow around turns. Keeping the cargo low is even more important in combination vehicles than in straight trucks.
- Keep the load centered on your rig. If the load is to one side, it can cause the trailer to lean and a rollover is more likely.

Figure 4-1  
Influence of  
Combination  
Type on  
Rearward  
Amplification



(From R.D. Ervin, R.L. Nisonger, C.C. MacAdam, and P.S. Fancher, "Influence of size and weight variables on the stability and control properties of heavy trucks", University of Michigan Transportation Research Institute, 1983.)

Trucks with trailers have a dangerous “crack-the-whip” effect. When you make a quick lane change, the crack-the-whip effect can turn the trailer over. There are many accidents where only the trailer has overturned.

“Rearward amplification” causes the crack-the-whip effect. Figure 4-1. Page 50 shows eight types of combination vehicles and the rearward amplification each has in a quick lane change. Rigs with the least crack-the-whip effect are shown at the top and those with the most are at the bottom. Rearward amplification of 2.0 in the chart means that the rear trailer is twice as likely to turn over as the tractor. You can see that triples have a rearward amplification of 3.5. This means you can roll the last trailer of triples 3.5 times as easily as a five-axle tractor-semi.

Steer gently and smoothly when you are pulling trailers. If you make a sudden movement with your steering wheel, you could tip over a trailer. Follow far enough behind other vehicles (at least one second for each ten feet of your vehicle length, plus another second if going over 40 mph). Look far enough down the road to avoid being surprised and having to make a sudden lane change. At night, drive slow enough to see obstacles with your headlights before it is too late to change lanes or stop gently. Slow down to a safe speed before going into a turn.

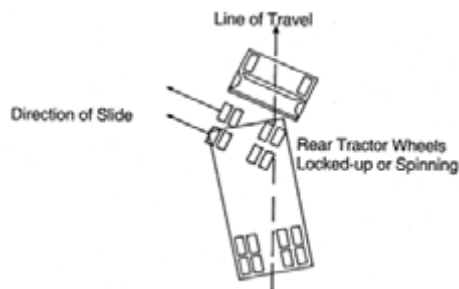

Figure 4-2 Tractor Jackknife

## Brake early

Control your speed whether fully loaded or empty. Large combination vehicles that are empty take longer to stop than when they are fully loaded. When lightly loaded, the very stiff suspension springs and strong brakes give poor traction and make it very easy to lock up the wheels. Your trailer can swing out and strike other vehicles. Your tractor can jackknife very quickly. See Figure 4-2.

You also must be very careful about driving “bobtail” tractors (tractors without semi-trailers). Tests have shown that bobtails can be very hard to stop smoothly. It takes them longer to stop than a tractor-semi trailer loaded to maximum gross weight.

In any combination rig, allow a lot of following distance and look far enough ahead so you can brake early. Don't be caught by surprise and have to make a “panic” stop.

## Prevent trailer skids

When the wheels of a trailer lock up, the trailer will tend to swing around. This is more likely to happen when the trailer is empty or lightly loaded. This type of jackknife is often called a “trailer jackknife.” This is shown to the right.

## Recognizing the skid

The earliest and best way to recognize that the trailer has started to skid is by seeing it in your mirrors. Any time you

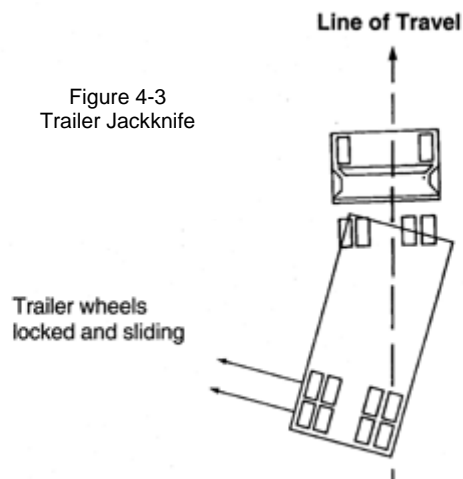

Figure 4-3 Trailer Jackknife

apply the brakes hard, check the mirrors to make sure the trailer is staying where it should. Once the trailer swings out of your lane, it is very difficult to prevent a jackknife.

### **Stop using the brake**

Release the brakes to get traction back. Do not use the trailer hand brake (if you have one) to straighten out the rig. This is the wrong thing to do, since the brakes on the trailer wheels caused the skid in the first place. Once the trailer wheels grip the road again, the trailer will start to follow the tractor and straighten out.

# Section 5 - Pre-Trip Vehicle Inspection Test

This section covers internal and external inspections. During the pre-trip inspection, you must show that the vehicle is safe to drive. You will have to walk around the vehicle and point to or touch each item and explain to the examiner what you are checking and why. You may not have to crawl under the hood or under the vehicle. It is important to inspect your truck or bus prior to leaving on a trip for safety reasons.

## All Vehicles

Study the following vehicle parts for the type of vehicle you will be using during the non-commercial skills test. You should be able to identify each part and tell the examiner what you are looking for or inspecting.

### Engine Compartment Only

- **Leaks/Hoses/Wiring**
  - Look for puddles on the ground.
  - Look for dripping fluids on the underside of the engine and transmission.
  - Inspect hoses for condition and leaks.
  - Look for worn electrical wiring insulation.
  
- **Oil Level**
  - Indicate where the dipstick is located.
  - See that the oil level is within safe operating range. Level must be above refill mark.
  
- **Coolant Level**
  - Inspect reservoir sight glass; or
  - If engine is not hot, remove the radiator cap and check for visible coolant level.
  
- **Power Steering Fluid**
  - Indicate where power steering fluid dipstick is located.
  - Check for adequate power steering fluid level. Level must be above refill mark.
  
- **Engine Compartment Belts**
  - Check the following belts for snugness (up to  $\frac{3}{4}$  inch play at center of belt), cracks, or frays.
    - Power steering belt
    - Alternator belt
    - Air compressor belt

**Note - if any of the components listed above are not belt-driven, you must tell the examiner which component(s) are not belt-driven and ensure the component(s) are operating properly (not damaged or leaking) and are mounted securely.**

## Cab Check/Engine Start

- **Oil Pressure Gauge**
  - Make sure the oil pressure gauge is working.
  - Check that pressure gauge shows increasing or normal oil pressure or that the warning light goes off.
  - If equipped, the oil temperature gauge should begin a gradual rise to the normal operating range.
- **Ammeter/Voltmeter**
  - Check that gauges show the alternator and/or the generator is charging or that warning light is off.
- **Mirrors and Windshield**
  - Mirrors should be clean and adjusted properly from the inside.
  - Windshield should be clean with no illegal stickers, no obstructions, or damage to the glass.
- **Wipers/Washers**
  - Check that wiper arms and blades are secure, not damaged, and operate smoothly.
  - If equipped, windshield washers must operate correctly.
- **Horn**
  - Check that the air horn and/or electric horn are in working condition.
- **Heater/Defroster**
  - Test that the heater and defroster work.

## Air Brake Check (if equipped)

*Failure to perform an air brake check will result in an automatic failure of the vehicle inspection test.* Air brake safety devices vary. However, this procedure is designed to see that any safety device operates correctly as air pressure drops from normal to a low air condition. For safety purposes, in areas where an incline is present, you will use wheel chocks during the air brake check. The proper procedures for inspecting the air brake system are as follows:

- With the engine running, build the air pressure to governed cut-out (100-125 psi).
- Shut off the engine, turn key to ON position.
- Chock the wheels.
- If necessary, release the tractor protection valve and parking brake, push in valves.
- Fully apply the foot brake and hold it for one minute.
- Check the air gauge to see if the air pressure drops more than three pounds in one minute (single vehicle) or four pounds in one minute (combination vehicles).
- Begin fanning off the air pressure by rapidly applying and releasing the foot brake. The low air warning device should activate before the air pressure drops below 60 psi.
- Continue to fan off the air pressure. At approximately 40 psi on a tractor-trailer combination vehicle, the tractor protection valve and parking brake valve should close

(pop out). On other combination and single vehicle types, the parking brake valve should close (pop out).

## **Light/Reflectors**

Check that all external lights and reflective equipment are clean and functional. Light and reflector checks include the following:

- Clearance lights (red on rear, amber elsewhere)
- Headlights (low and high beams)
- Taillights
- Turn signals
- 4-way flashers
- Brake lights
- Red reflectors on rear, and amber reflectors elsewhere

Note: Checking of brakes, turn signals, and 4-way flasher functions must be done separately.

## **Wheels**

The following must be inspected on every vehicle:

- **Rims** – Check for damage or bent rims. Rims cannot have welding repairs.
- **Lug nuts** – Check that all lug nuts are present, free of cracks and distortions such as rust trails or shiny threads. Make sure bolt holes are not cracked or distorted. Ensure there are no signs of looseness.
- **Tread depth** – Check for minimum tread depth: 4/32” on steering axle tires, and 2/32” on all other tires.
- **Tire condition** – Check that tread is evenly worn and look for cuts or other damage to tread or sidewalls. Also make sure that valve caps and stems are not missing, broken, or damaged.
- **Tire inflation** – Check for proper inflation by using a tire gauge, or by striking tires with a mallet or other similar device.

Note: You will not get credit if you simply kick the tires to check for proper inflation.

## **Tractor/Coupling**

- **Air/Electric Lines**
  - Listen for air leaks.
  - Check that air hoses and electric lines are not chafed, spliced, or worn. The steel braid should not show through.
  - Make sure air and electric lines are not tangled, pinched, or dragging against tractor parts.

- **Mounting Bolts**
  - Look for loose or missing mounting brackets, clamps, bolts, or nuts. Both the fifth wheel and the slide mounting must be solidly attached.
  - On other types of coupling systems (ball hitch, pintle hook, etc.) inspect all coupling components and mounting brackets for missing or broken parts.
  - Rings – These connect the trailer to the pintle hook. Inspect the ring for cracks, excessive wear, or other damage.
  - Safety Latch – This keeps the hook and ring from separating. Check to make sure the latch is in the down position and locked. Ensure it is not loose or damaged.
  
- **Locking Jaws**
  - Look into fifth wheel gap and check that locking jaws are fully closed around the kingpin.
  - On other types of coupling systems (ball hitch, pintle hook, etc.) inspect the locking mechanism for missing or broken parts and make sure it is locked securely. If present, safety cables or chains must be secure and free of kinks and excessive slack.
  
- **Platform (fifth wheel)** – Check for cracks or breaks in the platform structure that supports the fifth wheel skid plate.
  
- **Release Arm (fifth wheel)** – If equipped, make sure the release arm is in the engaged position and the safety latch is in place.
  
- **Kingpin/Apron/Gap/Trailer Tongue**
  - Check that the kingpin is not bent.
  - Make sure the visible part of the apron is not bent, cracked, or broken.
  - Check that the trailer is laying flat on the fifth wheel skid plate (no gap).
  
- **Locking Pins**
  - If equipped, look for loose or missing pins in the slide mechanism of the sliding fifth wheel. If air powered, check for leaks.
  - Make sure locking pins are fully engaged.
  - Check that the fifth wheel is positioned properly so that the tractor frame will clear the landing gear during turns.
  - On other types of coupling systems, inspect the trailer tongue to ensure it is not bent, cracked, or otherwise damaged.

## **Trailer**

- **Air/Electrical Connections (trailer front)**
  - Check that trailer air connectors are sealed and in good condition.
  - Make sure glad hands are locked in place, free of damage, or air leaks.
  - Make sure the trailer electrical plug is firmly seated and locked in place.
  
- **Tandem Release Arm/Locking Pins** – If equipped, make sure the locking pins are fully engaged and in the proper position. Ensure it is not worn, rusted, or damaged.



# Section 6 - Basic Vehicle Control Skills Test

Your basic control skills will be tested using all of the following exercises, off-road or somewhere on the street during the road test:

1. Forward Stop
2. Straight line backing
3. Alley dock

These exercises are show in Figures 6-1 through 6-3.

## Scoring

### Cross boundaries

The examiner will score the number of times you touch or cross over an exercise boundary line with any portion of your vehicle. Each encroachment will count as an error.

### Pull-ups

In some of the exercises, the examiner will also score the number of times you stop and change direction or pull-up during the exercise.

## Exercises

**Forward Stop** – You will be asked to drive forward between two rows of cones and bring your vehicle to a complete stop as close as you can to the exercise boundary marked by an end line or set of cones (without going beyond the line of cones). See figure 6-1 to the right.

Figure 6-1  
Forward Stop

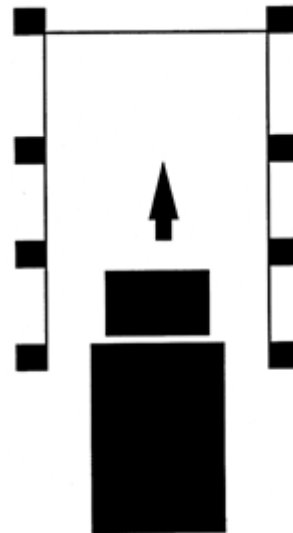

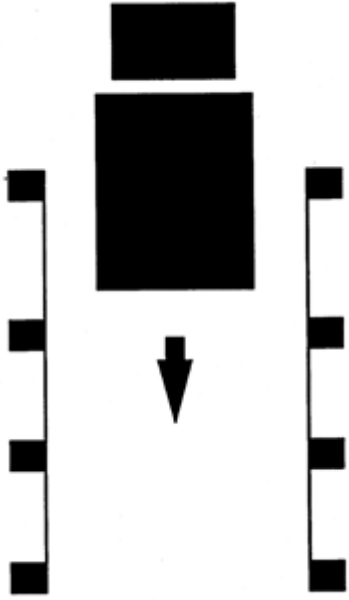

**Straight line backing** – You will be asked to back your vehicle in a straight line between two rows of cones without touching or crossing over the exercise boundaries.

Figure 6-2  
Straight Line  
Backing

**Alley dock** – You will be asked to sight-side back your vehicle into an alley, bring the rear of your vehicle as close as possible to the rear of the alley without going beyond the exercise boundary marked by a line or row of cones.

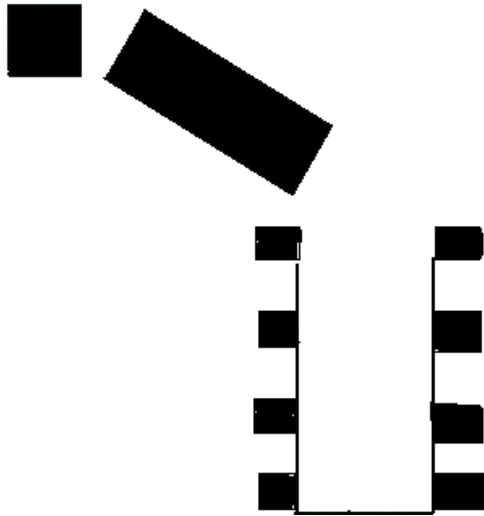

Figure 6-3  
Alley Dock

# Section 7 - On-Road Driving Test

## Exercises

During the driving test, you must wear your safety belt, obey all traffic signs, signals, and laws, and complete the test without an accident or moving violation.

You will drive over a test route that has a variety of traffic situations. At all times during the test, you must drive in a safe and responsible manner.

The examiner will score you on specific driving maneuvers as well as on your general driving behavior during the test. The examiner will give you directions and you will have plenty of time to do what is asked. You will not be asked to drive in an unsafe manner.

You will be scored on your overall performance in the following general driving behavior categories:

### Clutch Usage (manual transmission)

- Always use your clutch to shift.
- Double-clutch if the vehicle is equipped with non-synchronized transmission.
- Do not rev or lug the engine.
- Do not ride the clutch to control the speed, coast with the clutch depressed, or “pop” the clutch.

### Gear Usage (manual transmission)

- Do not grind or clash gears.
- Select gear that does not rev or lug engine.
- Do not shift in turns and intersections.

### Brake Usage

- Do not ride or pump brake.
- Do not brake harshly – brake smoothly using steady pressure.

### Lane Usage

- Do not put vehicle over curbs, sidewalks, or lane markings.
- Stop behind stop lines, crosswalks, or stop signs.
- Complete a turn in the proper lane on a multiple lane road – vehicle should finish a left turn in the lane directly to the right of the center line.
- Finish a right turn in the right-most lane.
- Move to or remain in the right-most lane unless lane is blocked.

If your test route does not have certain traffic situations, you may be asked to simulate a traffic situation. You will do this by telling the examiner what you are or would be doing if you were in that traffic situation.

## How You Will Be Tested

### Turns

You have been asked to make a turn:

- Check traffic in all directions.
- Use your turn signals and safely get into the lane needed for the turn.

As you approach the turn:

- Use your turn signals to warn others of your turn.
- Slow down, smoothly change gears as needed to keep power, but do not coast unsafely. Unsafe coasting occurs when your vehicle is out of gear for more than the length of your vehicle.

If you must stop before making the turn:

- Come to a smooth stop without skidding.
- Come to a complete stop behind the stop line, crosswalk, or stop sign.
- If stopping behind another vehicle, stop where you can see the rear tires on the vehicle ahead of you (safe gap).
- Do not let your vehicle roll.
- Keep the front wheels aimed straight ahead.

When ready to turn:

- Check traffic in all directions.
- Keep both hands on the steering wheel during the turn.
- Do not change gears during the turn.
- Keep checking your mirror to make sure the vehicle does not hit anything on the inside of the turn.
- Vehicle should not move into oncoming traffic.
- Vehicle should finish turn in correct lane.

After turn:

- Make sure turn signal is off.
- Get up to speed of traffic, use turn signal, and move into right-most lane when safe to do so, if not already there.

### Intersections

As you approach an intersection:

- Check traffic thoroughly in all directions (we're looking for head movement).
- Decelerate gently.
- Brake smoothly, and if necessary, change gears.
- If necessary, come to a complete stop (no coasting) behind any stop signs, signals, sidewalks, or stop lines, maintaining a safe gap behind any vehicle in front of you.
- Your vehicle must not roll forward or backward.

When driving through an intersection:

- Check traffic thoroughly in all directions.
- Decelerate and yield to any pedestrians and traffic in the intersection.
- Do not change lanes or shift gears while proceeding through the intersection.

- Keep your hands on the wheel.

Once through the intersection:

- Continue checking traffic.
- Accelerate smoothly and change gears as necessary.

### Urban and Rural Straight

During this part of the test, you are expected to make regular traffic checks and maintain a safe following distance. Your vehicle should be centered in the proper lane (right-most lane), and you should keep up with the flow of traffic but not exceed the posted speed limit.

### Urban and Rural Lane Changes

During the multiple lane portions of the urban and rural sections, you will be asked to change lanes to the left and then back to the right. You should make the necessary traffic checks first, then use proper signals and smoothly change lanes when it is safe to do so.

### Stop and Start

For this maneuver, you will be asked to pull your vehicle over to the side of the road and stop as if you were going to get out and check something on your vehicle. You must check traffic thoroughly in all directions and move to the right-most lane or shoulder of the road.

As you prepare to stop:

- Check traffic.
- Activate your right-turn signal.
- Decelerate smoothly, brake evenly, change gears as necessary.
- Bring your vehicle to a full stop without coasting.

Once stopped:

- Vehicle must be parallel to the curb or shoulder of the road and safely out of the traffic flow.
- Vehicle should not be blocking driveways, fire hydrants, intersections, signs, etc.
- Cancel your turn signal.
- Activate your 4-way emergency flashers.
- Apply the parking brake.
- Move the gear shift to neutral or park.
- Remove your feet from the brake and clutch pedals.

When instructed to resume:

- Check traffic and your mirrors thoroughly in all directions.
- Turn off your 4-way flashers.
- Activate the left-turn signal.
- When traffic permits, you should release the parking brake and pull straight ahead.
- Do not turn the wheel before your vehicle moves.
- Check traffic from all directions, especially to the left.
- Steer and accelerate smoothly into the proper lane when safe to do so.
- Once your vehicle is back into the flow of traffic, cancel your left-turn signal.

## Curve

When approaching a curve:

- Check traffic thoroughly in all directions.
- Before entering the curve, reduce speed so further braking or shifting is not required in the curve.
- Keep vehicle in the lane.
- Continue checking traffic in all directions.

## Upgrade

As you approach the upgrade:

- Select the proper gear to maintain speed and not lug the engine.
- Check the traffic thoroughly in all directions and move to the right-most or curb lane.
- If legal to do so, use 4-way flashers if traveling too slowly for the flow of traffic.

## Downgrade

Before starting down the grade:

- Downshift as needed to help control engine speed and test brakes by gently applying the foot brake to ensure they are functioning properly.
- As your vehicle moves down the grade, continue checking traffic in all directions, stay in the right-most or curb lane, and if legal to do so, use 4-way flashers if your vehicle is moving too slowly for traffic.
- Increase following distance and observe the following downhill braking procedures:
  - Select a “safe” speed, one that is not too fast for the weight of the vehicle, length and steepness of the grade, weather, and road conditions.
  - Once a “safe” speed has been reached, apply the brake hard enough to feel a definite slowdown.
  - When speed has been reduced to 5 mph below the “safe” speed, release the brake.
  - Once speed has increased to the “safe” speed, repeat the procedure.

When operating any commercial vehicle, do not ride the clutch, race the engine, change gears, or coast while driving down the grade. At the bottom of the grade, be sure to cancel your 4-way flashers.

Not all test routes will contain an area of sufficient grade to test your skill adequately. Therefore, you may be asked to simulate (verbally) driving up and down a steep hill. You must be familiar with the upgrade/downgrade procedures so that you can explain and/or demonstrate them to the examiner at any time during the driving test.